

KATO

IC110R

CRAWLER CARRIER

AVAILABLE FOR
RENT OR SALE



www.atsequipment.com

FULL-ROTATING CRAWLER CARRIER

The KATO IC110R is a full-rotating, 11-ton payload capacity crawler carrier equipped with a 256-hp Cummins B6.7 engine. Designed for rugged terrain and tight spaces, it features 360-degree rotation, a 24,250 lb payload capacity, and high-traction rubber crawlers for low ground pressure.



Key Specifications

Engine:	Cummins B6.7 diesel, 256hp
Payload Capacity:	24,250 lbs
Operating Weight:	36,619 lbs
Dimensions:	18' 4" x 8' 9" x 8' 10"
Vessel Capacity:	8 cubic yards
Ground Pressure (Loaded):	6.17 psi
Travel Speed:	5.0 mph (low) / 7.5 mph (high)
Rotation:	360-degree continuous

Key Features

Performance:	20-degree gradeability and 65-degree dump angle
Cabin:	ROPS/TOPS enclosed cabin with A/C, heating, and a 2-step slide seat
Operation:	Joystick controls for travel and rotation
Structure:	Low/narrow design for tight spaces with a 24" ground clearance
Safety:	Rear/side camera and overload alert

ATS EQUIPMENT INC. Construction Equipment & Supplies Rentals • Sales • Service

BOSTON, MA
(617) 825-3600

AUBURN, MA
(508) 832-8500

REHOBOTH, MA
(508) 379-6200

CANDIA, NH
(603) 483-2100

AVAILABLE FOR RENT OR SALE

KATO IC110R

FULL-ROTATING CRAWLER CARRIER



www.atsequipment.com

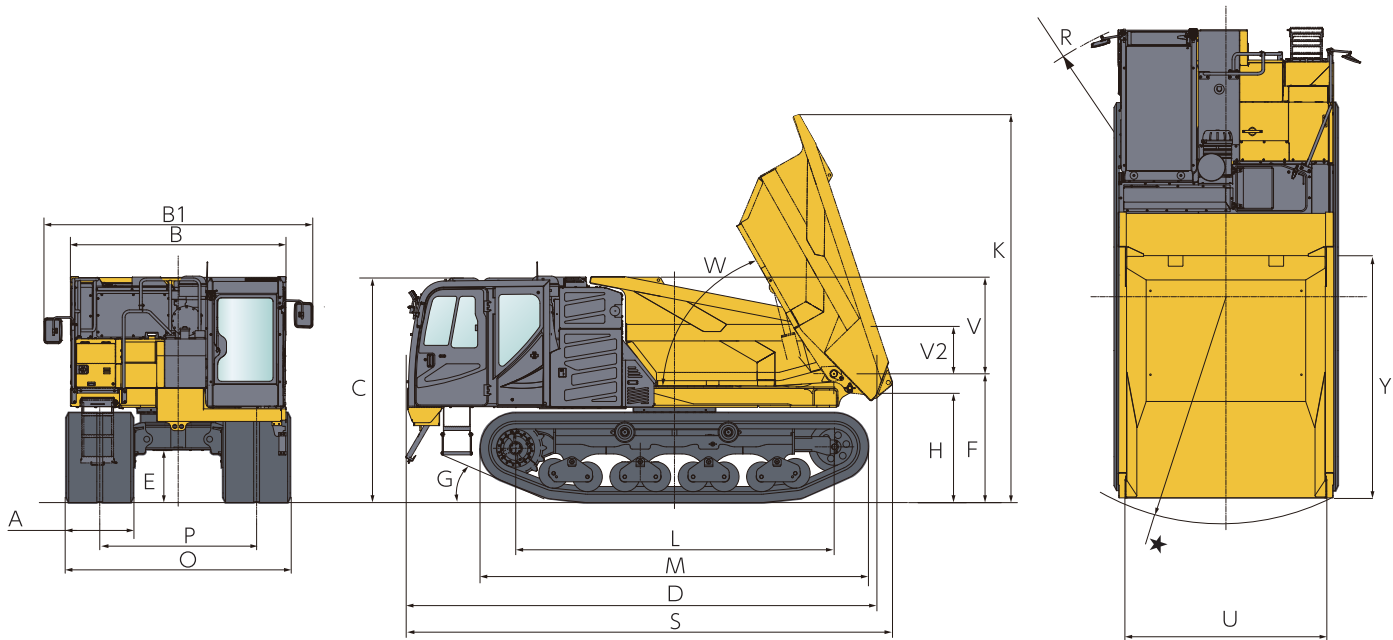

DIMENSIONS

Vessel Spec			Scoop End
B	Upper Machine Width	Without Mirrors	8' 5 1/4"
B1		With Mirrors	10' 6 1/4"
C	Overall Height		8' 10 1/4"
D	Overall Length		18' 4"
E	Ground Clearance		2' 0 1/2"
F	Vessel Bottom Height		5' 1"
Y	Vessel Dimensions (Inside)	Length	9' 5 3/4"
U		Width	7' 9 1/4"
V		Height (Front)	3' 8 7/8"
V2		Height (Back)	2' 0 1/2"
G	Approach Angle		23°
R	Swinging Radius		11' 4"
★	Vessel Swinging Radius		8' 11"

RAISED VESSEL DIMENSIONS

S	Overall Length	19' 0"
K	Overall Height	15' 2 1/4"
H	Vessel Opening Height	4' 1 5/8"
W	Vessel Raise Angle	60°

CRAWLER DIMENSIONS

L	Roller Distance	12' 5 5/8"		
M	Crawler Overall Length	15' 2 1/4"		
O	Crawler Overall Width	8' 9 1/8"		
P	Crawler Distance Apart	6' 1 5/8"	Shoe Pitch	5.91 in
A	Single Crawler Width	2' 7 1/2"	Number of Shoes	66 × 2

ATS EQUIPMENT INC. Construction Equipment & Supplies Rentals • Sales • Service

BOSTON, MA
(617) 825-3600

AUBURN, MA
(508) 832-8500

REHOBOTH, MA
(508) 379-6200

CANDIA, NH
(603) 483-2100