



CC900G

**AVAILABLE FOR
RENT OR SALE**



www.atsequipment.com

DOUBLE DRUM VIBRATORY ROLLER



Operating Mass: 2,800 lbs
SLL (front/rear): 34 / 44 lbs/in
Compaction width: 35 in

ATS EQUIPMENT INC. Construction Equipment & Supplies Rentals • Sales • Service

BOSTON, MA
(617) 825-3600

AUBURN, MA
(508) 832-8500

REHOBOTH, MA
(508) 379-6200

CANDIA, NH
(603) 483-2100

AVAILABLE FOR RENT OR SALE

DYNAPAC CC900G

DOUBLE DRUM VIBRATORY ROLLER



www.atsequipment.com

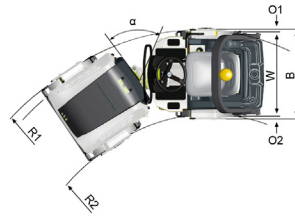
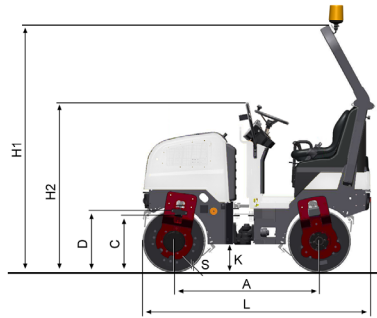

DIMENSIONS

DIMENSIONS

A. Wheelbase	53 in
B. Width	38 in
C. Curb clearance	18 in
D. Drum diameter	23 in
H1. Height, with ROPS/cab	91 in
H2. Height, w/o ROPS/cab	62 in
K. Ground clearance	10 in
L. Length	83 in
O1. Overhang, right	1 in
O2. Overhang, left	1 in
R1. Turning radius, outside	9 ft
R2. Turning radius, inside	6 ft
S. Drum shell thickness	0.4 in
W. Working width	35 in
α. Steering angle	±34°

STANDARD EQUIPMENT

Emergency stop, Horn, Hour meter, Ignition key, Warninglight for brakes, Warning light for hydraulic oil temp, Foldable ROPS (incl. seat belt), Seat safety switch, Sliding operator seat, Propulsion in both drums, Vibration on front drum, Towing eyelet (front/rear), Pressurized water system, Spring loaded scrapers

TECHNICAL DATA

WEIGHT

Max. operating weight	2,900 lbs
Operating mass (incl. ROPS)	2,800 lbs

COMPACTION

Centrifugal force	3,800 lbs
Nominal amplitude	0.016 in
Static linear load (front/rear)	34 /44 lbs/in
Vibration frequency	4,200 vpm
Water tank	50 gal

PROPULSION

Speed range	0-5 mph
Vertical oscillation	±6°
Max. theoretical gradeability	35 %

ENGINE

Manufacturer/Model	Honda GX630RH QYD
Rated power, SAE J1995	19 hp @ 3,000 rpm
Fuel tank capacity	6 gal

HYDRAULIC SYSTEM

Driving	Axial piston pump with variable displacement. 2 radial piston motors with constant displacement.
Vibration	Gear pump/motors with constant displacement.
Steering	Gear pump with constant displacement.
Service brake	Hydrostatic in forward and reverse lever.
Parking/Emergency brake	Failsafe brake in both drums.

ATS EQUIPMENT INC. Construction Equipment & Supplies Rentals • Sales • Service

BOSTON, MA
(617) 825-3600

AUBURN, MA
(508) 832-8500

REHOBOTH, MA
(508) 379-6200

CANDIA, NH
(603) 483-2100