



CC1200 VI

AVAILABLE FOR
RENT OR SALE



www.atsequipment.com

DOUBLE DRUM VIBRATORY ROLLER



Operating Mass: 5,700 lbs
SLL (front/rear): 58 / 64 lbs/i
Compaction width: 47 in

ATS EQUIPMENT INC. Construction Equipment & Supplies Rentals • Sales • Service

BOSTON, MA
(617) 825-3600

AUBURN, MA
(508) 832-8500

REHOBOTH, MA
(508) 379-6200

CANDIA, NH
(603) 483-2100

AVAILABLE FOR RENT OR SALE

DYNAPAC CC1200 VI

DOUBLE DRUM VIBRATORY ROLLER



www.atsequipment.com

DIMENSIONS

A. Wheelbase	67.0 in
B. Width	52.8 in
B3. Width, offset	1.968 in
C. Curb clearance	21.8 in
D. Drum diameter	27.6 in
H1. Height, with ROPS/cab	100.0 in
H2. Height, w/o ROPS/cab	68.7 in
K. Ground clearance	7.1 in
L. Length	94.5 in
O1. Overhang, right	2.8 in
O2. Overhang, left	2.8 in
R1. Turning radius, outside	148.4 in
R2. Turning radius, inside	101.2 in
S. Drum shell thickness	0.5 in
W. Working width	47.2 in
α. Steering angle	±30°

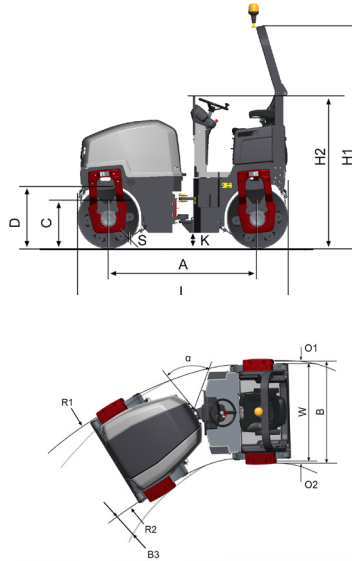

TECHNICAL DATA

WEIGHT

Max. operating weight	7,500 lbs
Operating weight (incl. ROPS)	5,700 lbs
Module weight (front/rear)	2,700 lbs/3,000 lbs

COMPACTION

Centrifugal force	34/29 kN
Nominal amplitude	0.020 in
Static linear load (front/rear)	10.3/11.4 kg/cm
Vibration frequency	66/61 Hz
Water tank	54 gal

PROPULSION

Speed range	0-10 km/h
Vertical oscillation	±10°
Max. theoretical gradeability	42 %

ENGINE

Manufacturer/Model	Kubota D1703-M (IIIA)
Type	Water cooled diesel engine
Rated power, SAE J1995	26 kW (35 hp) @ 2,800 rpm
Fuel tank capacity	12 gal

ENGINE

Manufacturer/Model	Kubota D1703-DI (T4/V)
Type	Water cooled diesel engine
Rated power, SAE J1995	18.5 kW (25 hp) @ 2,200 rpm

ENGINE

Manufacturer/Model	Kubota D1803-CR (T4/V)
Type	Water cooled diesel engine
Rated power, SAE J1995	28 kW (37.5 hp) @ 2,700 rpm

HYDRAULIC SYSTEM

Driving	Axial piston pump with variable displacement and servo. 2 radial piston motors with constant displacement.
Vibration	Gear pump/motors with constant displacement.
Steering	Gear pump with constant displacement.
Service brake	Hydrostatic in forward and reverse lever.
Parking/ Emergency brake	Failsafe multidisc brake in both drums.

ATS EQUIPMENT INC. Construction Equipment & Supplies Rentals • Sales • Service

BOSTON, MA
(617) 825-3600

AUBURN, MA
(508) 832-8500

REHOBOTH, MA
(508) 379-6200

CANDIA, NH
(603) 483-2100