



MISEBACH

LOAD BANKS

X100L

**AVAILABLE FOR
RENT OR SALE**



www.atsequipment.com

ULTRA LIGHT RESISTIVE LOAD BANK 100KW



Standard Features

1. Digital meter with USB-Type B dataport
2. Recessed control panel to protect controls
3. Voltage and temperature warning lamps
4. 400 amp camlock power connections
5. Lightweight aluminum body
6. 120V auxiliary power receptacle
7. Quiet, high-speed cooling fans

Applications

- Generator Maintenance
- Uninterrupted Power Supplies
- Data Centers
- Renewable Energy
- OEM's

Mosebach's X100L load bank offers you a continuous load at 480/240/208 volts in a compact, ultra lightweight, indoor enclosure.

The digital meter allows you to measure power, voltage, current and frequency while also allowing you to record the data as you do your testing.

Power connections are easily done with our camlock connections. Auxiliary power of 120V is used for blower and control power. You should be up and testing within minutes of connecting your power source.

ATS EQUIPMENT INC. Construction Equipment & Supplies Rentals • Sales • Service

BOSTON, MA
(617) 825-3600

AUBURN, MA
(508) 832-8500

REHOBOTH, MA
(508) 379-6200

CANDIA, NH
(603) 483-2100

AVAILABLE FOR RENT OR SALE

MOSEBACH X100L

ULTRA LIGHT RESISTIVE LOAD BANK 100KW



www.atsequipment.com

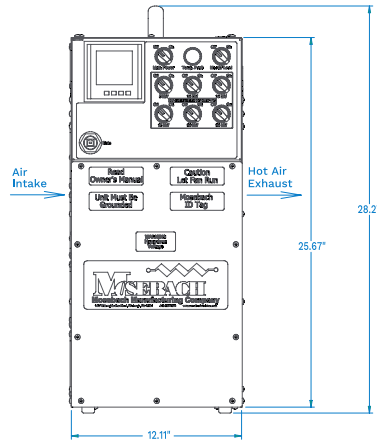
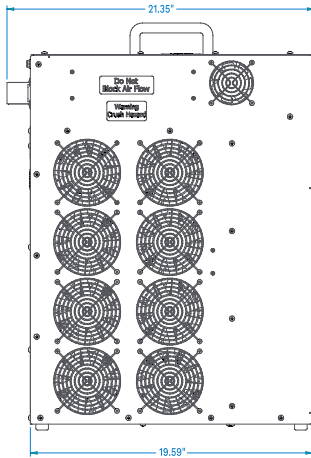

Ratings of X100L:

kW	VOLTAGE	RESOLUTION
■ 100	480	5
■ 100	240	5
■ 75	208	3.75
■ 66	240/1	3.3
■ 16.5	120/1	0.83

Standard Configuration

Digital Meter

- To measure current, voltage and frequency
- Data logging to store tests to laptop

Safety

- Over temperature and over voltage sensors
- Ground Camlock

Carrying Case

- 100% waterproof case
- Industrial strength injection molded case
- Gasket sealed, water and dust tight, submersible design
- Weight 38 lbs.

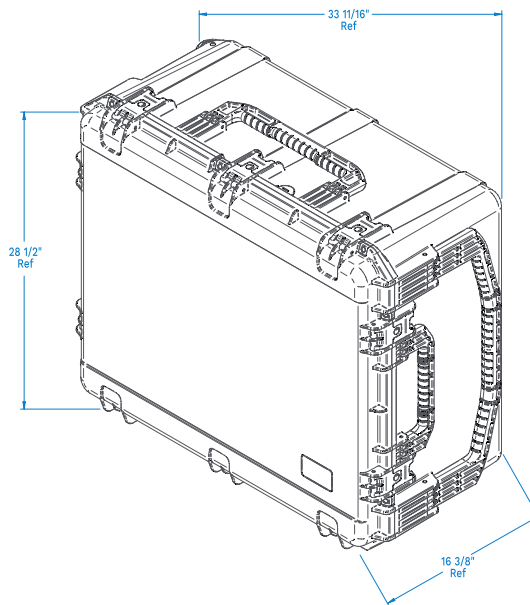
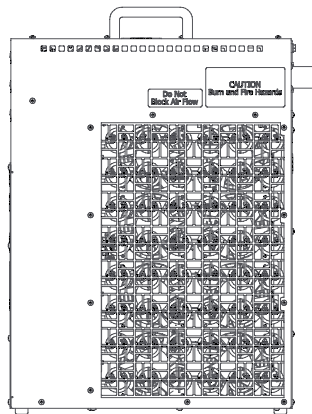

Model No.	Voltage	Total kW	Resolution (kW)	Dimensions L x W x H	Weight (lbs.)
X100L	480	100	5	20" x 12" x 29"	64

ATS EQUIPMENT INC. Construction Equipment & Supplies Rentals • Sales • Service

BOSTON, MA
(617) 825-3600

AUBURN, MA
(508) 832-8500

REHOBOTH, MA
(508) 379-6200

CANDIA, NH
(603) 483-2100