

WANCO[®]

WTSP55

AVAILABLE FOR
RENT OR SALE



www.atsequipment.com

15-LIGHT PORTABLE WANCO[®] ARROW BOARD

- Super-bright LED display
- 7 display patterns
- Energy efficient eco-friendly operation
- Large display is MTO approved
- Maintenance-free batteries

Reflective Sheeting

*Flapper Panels
in case of power failure*

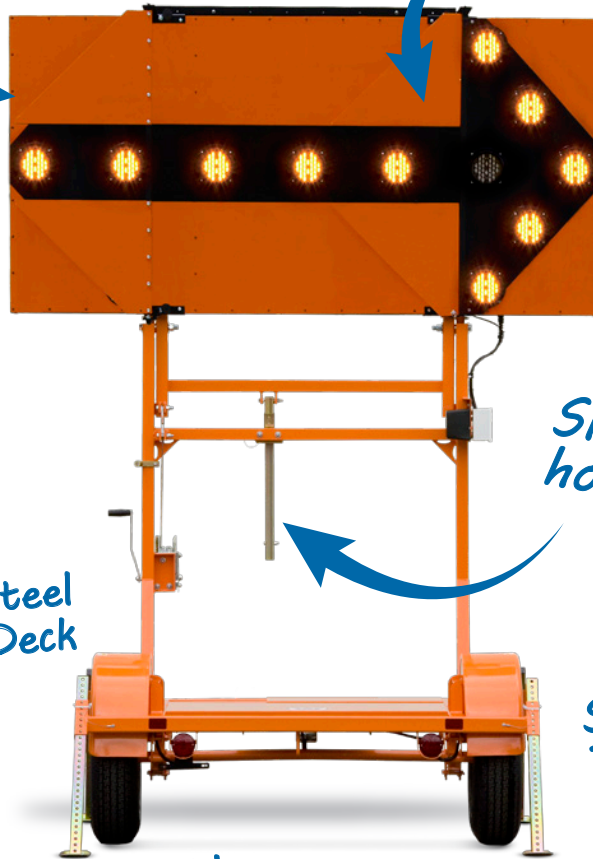

*Structural Steel
Frame and Deck*

*Slide-Bar
holds display panel*

*Standard
Trailer Tires*

*Removeable
Tow Bar*

ATS EQUIPMENT INC. Construction Equipment & Supplies Rentals • Sales • Service

BOSTON, MA
(617) 825-3600

AUBURN, MA
(508) 832-8500

REHOBOTH, MA
(508) 379-6200

CANDIA, NH
(603) 483-2100

AVAILABLE FOR RENT OR SALE

WANCO WTSP55

15-LIGHT PORTABLE WANCO® ARROW BOARD



www.atsequipment.com

Features

Environmental

- Maintenance-free batteries
- Consumes 80% less power than other solar arrow boards
- Smaller batteries have 80% less lead content
- Sealed batteries will not leak or spill
- Decreased charging time saves energy and downtime
- Manufacturing process emits near-zero VOCs
- Nearly every component can be recycled

Functional

- High-output amber LEDs legible up to 1 mile (1.6 km)
- Fully MTO compliant
- 15 lamps with 7 arrow display modes
- Easy to operate and maintain
- Heavy-duty hand-winch with safety brake allows one person to raise display panel
- Single locking device holds display panel in place while operating and during transport
- Controller located safely away from traffic
- Weather-resistant control box cover, lockable slam-latch
- Control box outputs have short-circuit protection, helping prevent blown transistors
- Positive-drive voltage system applies power to lamps only when lit
- Power system includes resetting dual circuit breakers, reverse polarity protection, and low-voltage disconnect
- Solar charging system features solid state voltage regulator with charge indicator
- Arrow display has automatic and manual dimming, with flash rates of 30 to 40 per minute
- In travel position, unique design supports board without rear braces, reducing possibility of damage during transport
- Durable powder-coat finish resists the elements
- Meets MUTCD
- NTPEP tested

Brief specifications

Display

| | |
|------------|--|
| Lights | Amber LEDs, 15 on front, 2 on back |
| Legibility | 1 mile (1.6km) max. legible distance |
| Winch | Hand-operated, raises and lowers display |
| Standards | Meets MUTCD Type C, MTO-approved |

Construction

| | |
|-----------------|---|
| Trailer | All welded structural steel |
| Display cabinet | Aluminum sheet and welded channels |
| Finish | Powder-coated and oven-baked |
| Axle assembly | 2000 lb. (907kg) capacity with 5-on-5.5" B.C. idler hub |
| Tires | ST205/75D15 trailer tires |

Power*

| | |
|------------------|---|
| Batteries | Two leak- and spill-proof, valve-regulated lead acid (VRLA) |
| Battery capacity | 48 Ah total |
| Battery voltage | 12 Vdc |
| Solar panel | 55 W |

*Standard power; many options available. Contact factory for details.

Dimensions

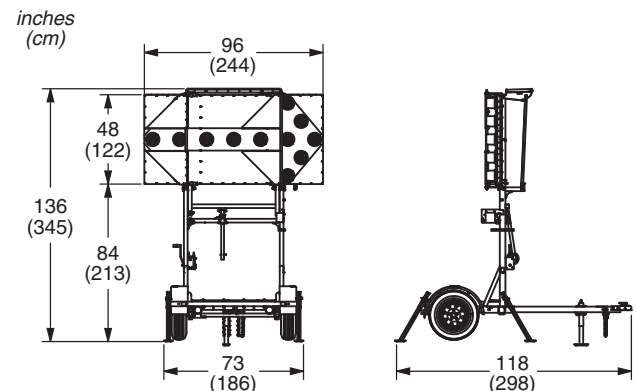

Travel height: 91 in. (230cm)

Weight

Approx. 1000 lbs. (453kg)

ATS EQUIPMENT INC. Construction Equipment & Supplies Rentals • Sales • Service

BOSTON, MA
(617) 825-3600

AUBURN, MA
(508) 832-8500

REHOBOTH, MA
(508) 379-6200

CANDIA, NH
(603) 483-2100