

AVAILABLE FOR RENT AT

ATS
EQUIPMENT INC.

www.atsequipment.com

KOMATSU *Utility*



PC09-1

**COMPACT HYDRAULIC EXCAVATOR
WITH TIER 2 ENGINE**

GALEO

ATS EQUIPMENT INC. Construction Equipment & Supplies Rentals • Sales • Service

**BOSTON, MA
(617) 825-3600**

**AUBURN, MA
(508) 832-8500**

**REHOBOTH, MA
(508) 379-6200**

**CANDIA, NH
(603) 483-2100**

KOMATSU UTILITY PC09-1

ATS EQUIPMENT INC.
www.atsequipment.com

COMPACT HYDRAULIC EXCAVATOR WITH TIER 2 ENGINE



OPERATING WEIGHT (APPROXIMATE)

Operating weight including 2'3" arm, bucket with 0.78 ft³ ISO 754 capacity, blade, operator weight, liquids, full fuel tank, and standard equipment.

PC09-1	Shoe Width	Operating Weight
With TOPS Canopy	7.0"	1,985 lb
With Breaker		2,070 lb



COOLANT AND LUBRICANT CAPACITY (REFILLING)

Fuel tank	2.9 U.S. gal
Coolant	0.6 U.S. gal
Engine oil	0.5 U.S. gal
Hydraulic tank	2.4 U.S. gal



DIMENSIONS

	Operating Weight	1,985 lb
A	Overall length	9'0"
B	Overall width with expandable undercarriage	2'4"-2'10"
C	Overall height	6'11"
D	Ground clearance (minimum)	6.7"
E	Tail swing radius	2'7"
F	Track width	7.0"

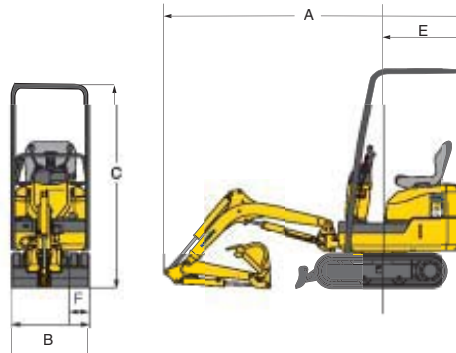

WORKING RANGE

	Arm length	2'3"
A	Max. digging depth	4'11"
B	Max. dumping height	6'6"
C	Max. digging height	9'2"
D	Max. vertical digging depth	3'10"
E	Max. digging reach at ground level	9'11"
F	Max. digging reach	9'4"
	Bucket breakout force	2370 lb

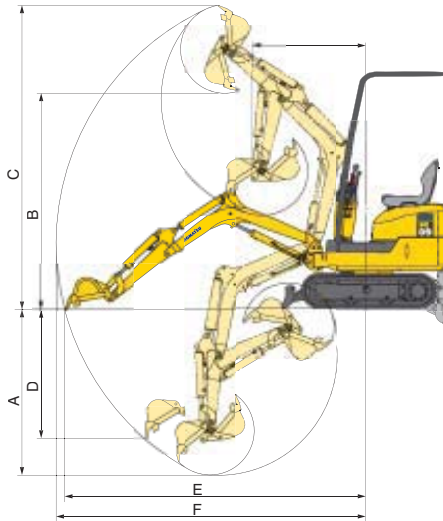

LIFTING CAPACITY

Unit: lbf

Arm Length		5'		Maximum	
		Front	Side	Front	Side
2'3"	5'	*493	*493 (454)	*452	317 (242)
	0'	*952	537 (403)	*493	291 (220)

*Load is limited by hydraulic capacity rather than tipping.
Rated loads do not exceed 87% of hydraulic capacity or 75% of tipping load.
() : with constricted gauge

ATS EQUIPMENT INC. Construction Equipment & Supplies Rentals • Sales • Service

BOSTON, MA
(617) 825-3600

AUBURN, MA
(508) 832-8500

REHOBOTH, MA
(508) 379-6200

CANDIA, NH
(603) 483-2100