

KOMATSU

AVAILABLE FOR RENT AT

ATS
EQUIPMENT INC.

www.atsequipment.com



Photos may include optional equipment.

PC18MR-2

COMPACT HYDRAULIC EXCAVATOR
NET HORSEPOWER 15 HP @ 2600 rpm
OPERATING WEIGHT 4,090 lb
AVAILABLE WITH 9" 12" AND 18" BUCKET



ATS EQUIPMENT INC. Construction Equipment & Supplies Rentals • Sales • Service

BOSTON, MA
(617) 825-3600

AUBURN, MA
(508) 832-8500

REHOBOTH, MA
(508) 379-6200

CANDIA, NH
(603) 483-2100

KOMATSU PC18MR-2

ATS EQUIPMENT INC.
www.atsequipment.com

COMPACT HYDRAULIC EXCAVATOR



DIMENSIONS

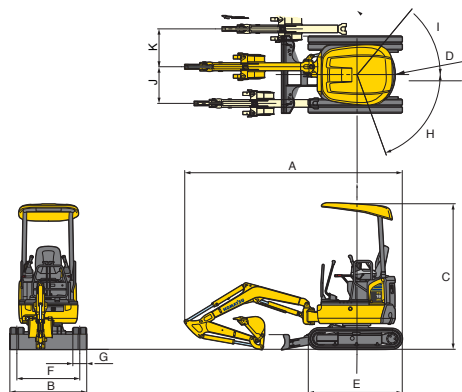

Dimensions	ft. in.
A. Overall length	12'0"
B. Overall width	3'3"-4'3"
C. Overall height	7'11"
D. Tail swing radius	2'4"
E. Crawler length	5'1"
F. Track gauge	2'6"-3'6"
G. Track shoe width	9.1"
H/I. Boom swing angle	LH 70 / RH 50
J/K. Bucket offset	LH 1'6" / RH 2'7"



WORKING RANGE

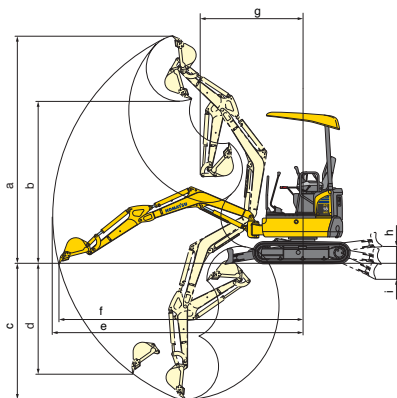

Standard Arm Working Range	3'2"	Long Arm Working Range	4'0"
a. Max. digging height	11'10"	a. Max. digging height	12'6"
b. Max. dumping height	8'7"	b. Max. dumping height	9'3"
c. Max. digging depth	7'1"	c. Max. digging depth	7'10"
d. Max. vertical digging depth	5'10"	d. Max. vertical digging depth	6'7"
e. Max. digging reach	13'2"	e. Max. digging reach	14'0"
f. Max. digging reach (ground level)	12'11"	f. Max. digging reach (ground level)	13'9"
g. Min. swing radius (when boom swing)	5'6" 4'5"	g. Min. swing radius (when boom swing)	5'10" 4'8"
h. Max. blade lift	11"	h. Max. blade lift	11"
i. Max. blade depth	10"	i. Max. blade depth	10"



LIFTING CAPACITIES

Blade on ground and expanded undercarriage

Arm Length	A B	6.5'		8.2'		10'		MAXIMUM	
		Front	Side	Front	Side	Front	Side	Front	Side
3'2"	10'							*782	*782
	6.5'			*701	*701	*692	518	*701	476
	3.2'	*1,440	928	*1,001	666	*809	505	*714	401
	0'	*1,777	873	*1,214	633	*908	487	*745	412
	-3.2'	*1,400	884	*983	637			*754	540
4'0"	0'	*1,759	869	*1,179	628	*890	483	*661	364

* Rated loads do not exceed 87% of hydraulic capacity or 75% of tipping load.

ATS EQUIPMENT INC. Construction Equipment & Supplies Rentals • Sales • Service

BOSTON, MA
(617) 825-3600

AUBURN, MA
(508) 832-8500

REHOBOTH, MA
(508) 379-6200

CANDIA, NH
(603) 483-2100