

AVAILABLE FOR
RENT OR SALE

IHI

17VXE

COMPACT EXCAVATOR

ATS
EQUIPMENT INC.

www.atsequipment.com

ELECTRIC EXCAVATOR 3 PHASE/480 VOLT



Standard Items:

- 18" Bucket
- Auxillary Piping ¹
- Additional Counter Weight ²
- Control Pattern Change Valve

Options:

- Buckets Sizes
8" 12" 24"
- 39" Ditch Clean Bucket
- 39" Swivel
- Blade Extensions ³
- Hydraulic Thumb
- Quick Coupler



1



2



3

ATS EQUIPMENT INC. Construction Equipment & Supplies Rentals • Sales • Service

BOSTON, MA
(617) 825-3600

AUBURN, MA
(508) 832-8500

REHOBOTH, MA
(508) 379-6200

CANDIA, NH
(603) 483-2100

AVAILABLE FOR RENT OR SALE

IHI 17VXE



COMPACT EXCAVATOR

www.atsequipment.com



- ⚡ 15 h.p./3phase/48 volt/ 50 amp Reuland Motor
- ⚡ Key start
- ⚡ E-Stop
- ⚡ Soft start protected



- ⚡ Reverse rotation protected
- ⚡ Low voltage protected
- ⚡ Low amperes protected
- ⚡ Over current protected
- ⚡ Ground fault protected

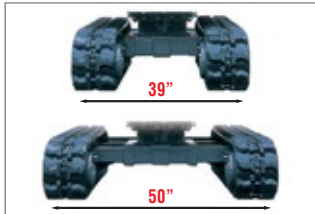

- ⚡ Hydraulic Controlled
- ⚡ Retracted is 39" total unit width
- ⚡ Expanded is 50" total unit width

Dimensions

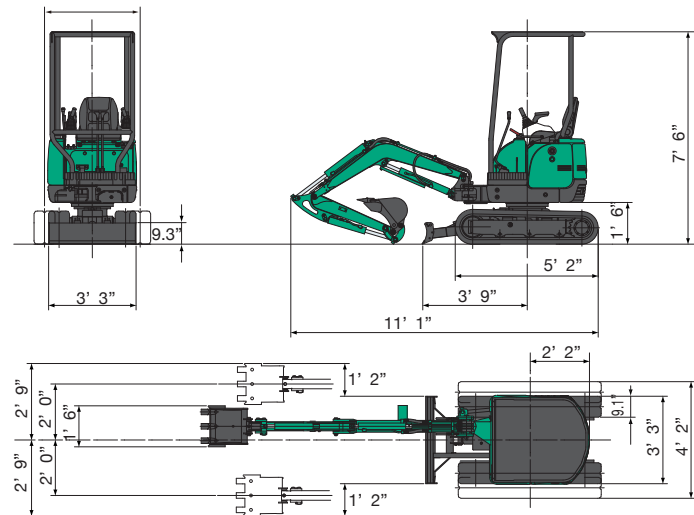

Working Range

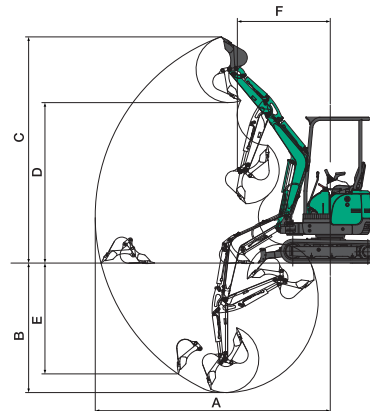

| | 4-Post Canopy |
|-------------------------------|---------------|
| A Max. digging radius | 12'4" |
| B Max. digging depth | 7'0" |
| C Max. digging height | 11'10" |
| D Max. dumping height | 8'5" |
| E Max. vertical digging depth | 5'10" |
| F Min. front turning radius | 4'11" |
| At right boom swing | 4'2" |

17VXE Specifications

| | | | |
|-------------------------------|---------------------------|---------------------------------------|---|
| Performance | | Boom swing system | |
| Bucket capacity | 1.6 cu. ft. | Type | Boom offset with hydraulic cylinder |
| Bucket width | 18" | Swing angle (L/R) | 55°/80° |
| Operating weight: 4-Post | 3,583 lbs. | Hydraulic system | |
| Transportation weight: 4-Post | 3,417 lbs. | Pressure | 3000 psi |
| Swing speed | 9.5 min ⁻¹ | Pump • type/hydraulic flow | 2 Piston/2 Gear • 4.5 gal/min x 2 + 3.2 gal/min |
| Travel speed (low/high) | 1.3/2.5 mph | Dozer blade | |
| Gradeability | 30° | Size | 37.8" x 9.3" |
| Ground pressure | 3.8 psi | Lift above ground / Drop below ground | 10.8"/12" |
| Max bucket digging force | 5,447 lbs. | Max auxiliary flow | |
| Motor | Rueland 15 H.P. 3PH. 480V | Auxiliary line | 7.7 gal/min |

ATS EQUIPMENT INC. Construction Equipment & Supplies Rentals • Sales • Service

BOSTON, MA
(617) 825-3600

AUBURN, MA
(508) 832-8500

REHOBOTH, MA
(508) 379-6200

CANDIA, NH
(603) 483-2100