



# FOUR STROKE VIBRATORY RAMMERS

AVAILABLE FOR RENT OR SALE



[www.atsequipment.com](http://www.atsequipment.com)



- Durable and Reliable
- Meets all EPA regulations for 4 cycle engines
- Low fuel consumption - low operating cost
- Well balanced - makes it easy to work with
- Protective hood - protects engine and reduces noise.
- Transport rollers - one person can move this unit around

## MS590

### MS590 SPECIFICATIONS

Shoe size 9" x 13"  
 Engine Honda GX100, 3.0 hp  
 Centrifugal force 2,995 lbf  
 Operating speed 49 - 59 ft/min  
 Operating weight 137.0 lbs

### DIMENSIONS

\*Contact area sq feet



## MS690

### MS690 SPECIFICATIONS

Shoe size 11" x 13"  
 Engine Honda GX100, 3.0 hp  
 Centrifugal force 3,330 lbf  
 Operating speed 49 - 59 ft/min  
 Operating weight 150.0 lbs

### DIMENSIONS

\*Contact area, m2 (sq feet).

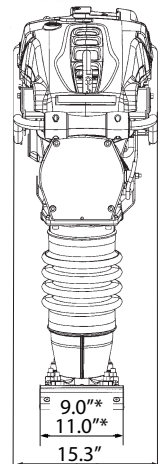
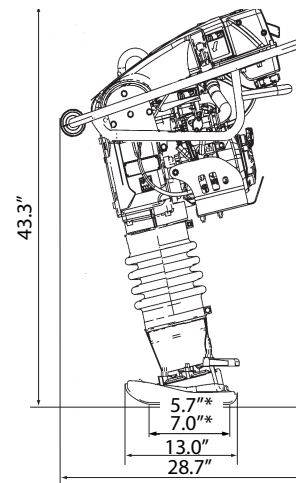
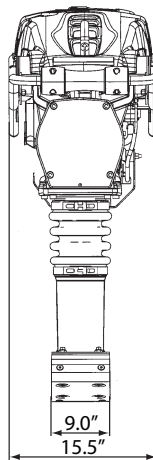
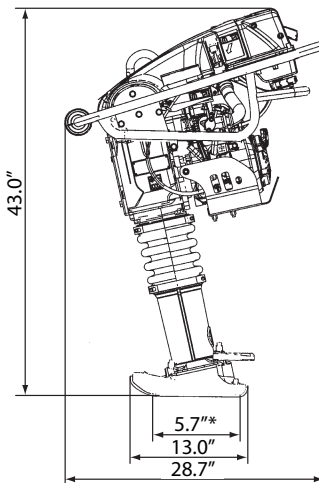

**ATS EQUIPMENT INC.**

**Construction Equipment & Supplies**

**Rentals • Sales • Service**

**BOSTON, MA**  
 (617) 825-3600

**AUBURN, MA**  
 (508) 832-8500

**REHOBOTH, MA**  
 (508) 379-6200

**CANDIA, NH**  
 (603) 483-2100