

**AVAILABLE FOR
RENT OR SALE**

SKYJACK™

SJ4740

40' ELECTRIC SCISSORS

**ATS
EQUIPMENT INC.**

www.atsequipment.com

INDUSTRY LEADERS

Skyjack electric scissor lifts have been recognized as an industry leader for over a decade. Our DC scissor lifts are ideal for indoor work where accuracy and precision turns around sensitive material is critical.

SKYCODED™

A proven and reliable control system, incorporating Skyjack's color coded and numbered wiring system, make our machines the easiest to trouble shoot and repair which means easier maintenance and lowered costs.

STANDARD FEATURES

- Drivable at full height
- Variable speed, front wheel hydraulic drive
- Dual holding brakes
- SKYCODED™ Color coded and numbered wiring system
- On-board visual interface with diagnostic capabilities
- Shroud style, impact resistant composite control box with extended cable
- Proportional controls for drive & lift functions
- Tilt Sensor (3.5° x 1.5°)
- 3' (0.91 m) Roll out extension deck
- 24V DC Power source
- Low voltage battery protection
- 25% Gradeability
- Solid rubber, non-marking tires
- Pothole protection system
- 110V AC Outlet on platform with GFI
- 28 mph (12.5 m/s) wind rating to 24' (7.32 m)
- Tilt alarm with drive & lift cut-out
- All motion audible alarm
- Lanyard attachment points

- Operator horn
- Forklift pockets and tie down /lift lugs
- Overload sensing system
- Fold down hinged railing system
- Half height spring hinged entry gate
- Telematics ready
- 5-Year parts warranty on standard charger and controller

† Standard lead times may be increased when optional equipment is added, consult factory.

‡ Capacities and machine weights may differ when options are added.

* Only available with ELEVATE telematics



ATS EQUIPMENT INC. Construction Equipment & Supplies Rentals • Sales • Service

**BOSTON, MA
(617) 825-3600**

**AUBURN, MA
(508) 832-8500**

**REHOBOTH, MA
(508) 379-6200**

**CANDIA, NH
(603) 483-2100**

SKYJACK™

SJ4740

40' ELECTRIC SCISSORS

AVAILABLE FOR
RENT OR SALE



www.atsequipment.com

Dimensions	SJ4740
A Work Height	44' 11"
B Raised Platform Height	38' 11"
C Lowered Platform Height	56"
D Overall Width	47"
E Overall Length (Platform Retracted)	94.5"
F Stowed Height (Rails Up)	99.5"
G Stowed Height (Rails Down)	79.5"
H Platform Width (Inside Railing)	42"
I Platform Inside Length (Retracted)	86"
Specifications	SJ4740
Extension Deck (Roll Out)	3'
Ground Clearance (Pothole Raised)	4.5"
Ground Clearance (Pothole Deployed)	0.5"
Wheelbase	73"
Weight	6,467 lbs
Gradeability	25%
Turning Radius (Inside)	17.5"
Turning Radius (Outside)	99"
Lift Time (With Rated Load)	68 sec
Lowered Time (With Rated Load)	41 sec
Drive Speed (Stowed)	1.9 mph
Drive Speed (Raised)	0.5 mph
Maximum Drive Height	Full Height
Capacity (Overall)	770 lbs
Distributed Capacity (Main Platform)	505 lbs
Distributed Capacity (Extension Deck)	265 lbs
Local Floor Load (With Rated Load)	139 psi
Overall Floor Load (With Rated Load)	233 psf
Maximum # of persons at 0 mph (0 m/s) wind rating	3
Maximum # of persons up to 28 mph (12.5 m/s) wind rating	1 up to 24'
Tire Type	Solid, N/M
Tire Size	16 x 5 x 12

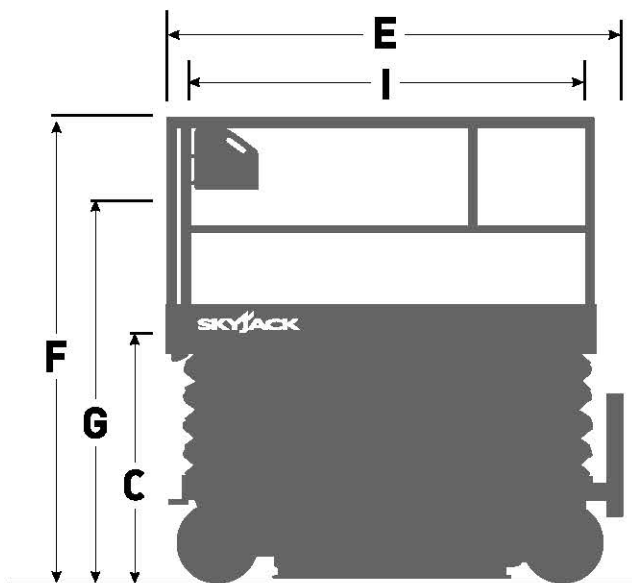
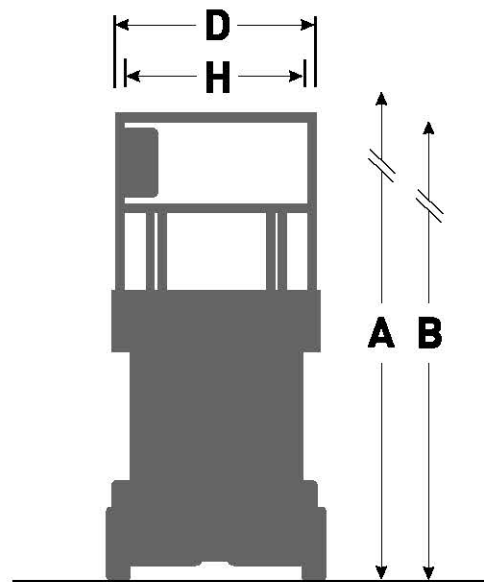

ATS EQUIPMENT INC. Construction Equipment & Supplies Rentals • Sales • Service

BOSTON, MA
(617) 825-3600

AUBURN, MA
(508) 832-8500

REHOBOTH, MA
(508) 379-6200

CANDIA, NH
(603) 483-2100