

KOMATSU SK815-5

SKID STEER LOADER

AVAILABLE FOR RENT AT



www.atsequipment.com



NET HORSEPOWER: 54 HP @ 2800 rpm
OPERATING WEIGHT: 5,785 lb

ATTACHMENTS AVAILABLE



GRAPPLE



HAMMER



AUGER



PALLET FORK



HARLEY RAKE



SWEEPER



CONCRETE BUCKET

ATS EQUIPMENT INC.

Construction Equipment & Supplies

Rentals • Sales • Service

BOSTON, MA
(617) 825-3600

AUBURN, MA
(508) 832-8500

REHOBOTH, MA
(508) 379-6200

CANDIA, NH
(603) 483-2100

KOMATSU SK815-5

ATS EQUIPMENT INC.
www.atsequipment.com

SKID STEER LOADER



DIMENSIONS

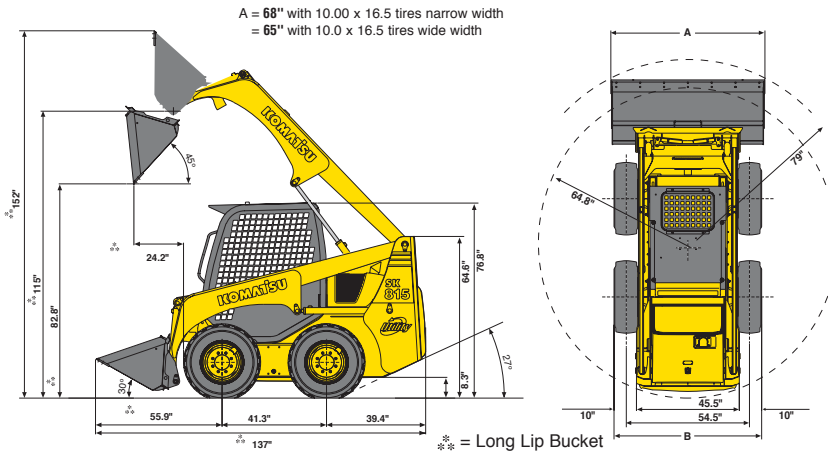

Bucket		Base Machine with 278 lb. Counterweights 68" Long Lip Bucket
Bucket capacity	SAE rated	0.56 yd³
Bucket width		68"
Bucket weight		387 lb
Operating capacity - 50% of tipping load		1,750 lb
Dump clearance, maximum height and 45° dump angle		82.8"
Height to bucket hinge pin		115"
Reach at maximum height and 45° dump angle		24.2"
Operating height	Fully raised	152"
Clearance circle-front		79"
Clearance circle-rear		64.8"
Operating weight		6,050 lb

ENGINE-EPA TIER 2 CERTIFIED

Model Komatsu S4D84E-1FD

Rated power:

(SAE J1349) 54 HP @ 2800 rpm

Max. torque 116 ft. lb. @ 1800 rpm

Speeds: Working 6.5 mph

Speeds: Travel 10.0 mph

HYDRAULIC SYSTEM

Type Komatsu

Pump Gear

Max. flow - auxiliary hydraulic 16.1 gal/min

Max. pressure - auxiliary hydraulic 2,770 psi

Control valve 3 elements fully Servo-controlled

Fuel tank 14.0 US gal.

OPERATING WEIGHT

Operating weight of machine with standard bucket, full tank of fuel and an 176 lb operator (ISO 6016) 5,785 lb

OPTIONAL EQUIPMENT

- 12 volt electrical outlet
- Amber rotating beacon
- Auxiliary hydraulics over-ride control
- Control pattern change valve
- Lifting hooks on cab roof
- Master electrical disconnect switch
- Rear counterweights
- SUPERFLOW auxiliary hydraulics version, with additional auxiliary hydraulic circuit for attachments
- Suspension seat
- Working lights (2 rear)

ATS EQUIPMENT INC. Construction Equipment & Supplies Rentals • Sales • Service

BOSTON, MA
(617) 825-3600

AUBURN, MA
(508) 832-8500

REHOBOTH, MA
(508) 379-6200

CANDIA, NH
(603) 483-2100