

# KOBELCO

**DRIVEN BY  
PASSION**

Hydraulic Excavators

# SK350 LC

■ Bucket Capacity :  
1.57 - 2.50 cu.yd. SAE

■ Engine Power :  
270 hp {201 kW} / 2,100 rpm  
(SAE NET)

■ Operating Weight :  
81,800 lbs {37,100 kg}



Note: This catalog may contain attachments and optional equipment that are not available in your area. It may also contain photographs of machines with specifications that differ from those of machines sold in your area. Please consult your nearest KOBELCO distributor for those items you require. Due to our policy of continuous product improvements all designs and specifications are subject to change without advance notice. Copyright by **KOBELCO CONSTRUCTION MACHINERY CO., LTD.** No part of this catalog may be reproduced in any manner without notice.

## **KOBELCO CONSTRUCTION MACHINERY U.S.A. INC.**

4690 World Houston Parkway Houston, TX 77032  
<http://www.kobelco-usa.com/>

Inquiries To:

Bulletin No. SK350LC-9-NA-201

2013080000E Printed in USA



# The Power Wave of Change

"Genuine KOBELCO is Back!" excavators provide the three E's:

Enhancement, Economy and Environment!

The refining of each of these "E's", together with the introduction of leading-edge technology that complies with US EPA Interim Tier 4 emission standards provides excavators with even more enhanced environmental performance and fuel efficiency, as well as unparalleled work performance.

The incredible work rate of these excavators is provided by powerful digging strength and a wide digging range. These excavators feature a Hino engine with reduced environmental impact and Kobelco's unique technology that reduces pressure-loss resistance.

Kobelco's reliable and well-tested technology has been developed over many years, making it more than capable of satisfying the various demands of today's construction industry.

Continuously creating original value, Kobelco has been able to bring technical marvels into existence through a spirit of perpetual pursuit.

## Enhancement

### Greater Performance Capacity

- Reduced fuel consumption with highly efficient productivity
- New environmental engine with superior fuel efficiency and low fuel consumption hydraulic circuitry
- Powerful arm bucket digging strength and wide digging range

## Economy

### Improved Cost Efficiency

- Adoption of new "ECO-Mode" greatly reduces fuel consumption
- Easy maintenance that reduces upkeep costs
- High structural durability and reliability that retain machine value longer

## Environment

### Features That Go Easy on the Earth

- Compliance with US EPA Interim Tier IV regulations
- Low-noise and low vibration including improvements to sound quality

### Fuel Consumption Rate

(Comparison with ACERA MARK 8 in S-Mode/Eco-Mode)

- **25%**  
approximately

### PM Reduction Rate

- **88%**  
approximately

### Digging Volume per Liter of Fuel

(Comparison with ACERA MARK 8 in S-Mode/Eco-Mode)

+ **23%**  
approximately



# More Work with Less Fuel!

## Top-Class Powerful Digging (SAE J 1179:1990)

- Max. arm crowding force: 37,100 lbs {160kN}
- Max. arm crowding force with power boost: 39,600 lbs {176kN}
- Max. bucket digging force: 44,700 lbs {199kN}
- Max. bucket crowding force with power boost: 49,200 lbs {219kN}

## Great Swing Power, Short Cycle Times

- Swing speed: 10.0 rpm

## Powerful Travel

- Drawbar pulling force: 72,200 lbs {321kN}

## Digging Volume per Liter of Fuel

(Comparison with ACERA MARK 8 in S-Mode/Eco-Mode)

+ approximately 23%

- H-Mode : + approximately 16%
- S-Mode : + approximately 12%

## Energy Saving System

### Fuel Consumption Rate

(Comparison with ACERA MARK 8 in S-Mode/Eco-Mode)

- approximately 25%

### Hydraulic Circuit with Reduced Energy Loss

The KOBELCO original hydraulic circuit analysis is used to construct the hydraulic system with extremely reduced energy loss that contains a piping design for minimal back pressure losses resistance and the minimum valve resistance.



### ECO-Mode

The ECO-mode is newly provided in this machine. The control of the engine and hydraulic pressure in this mode makes a significant reduction in fuel consumption possible. Each mode for each work situation and circumstance can be selected easily from the menu.

### Each Mode Reduces Fuel Consumption (Comparison with Previous Model)



- H** H-Mode approximately 16% ↓  
Suitable for a heavy workload
- S** S-Mode approximately 11% ↓  
Suitable for a good balance between workload and fuel consumption
- E** **NEW** ECO-Mode approximately 15% ↓  
Suitable for a severe priority on low fuel consumption at a light workload

## Eco-Friendly Engine (No exhaust fluid required)

### PM Reduction Rate

- approximately 88%

### A State of The Art Developed Engine

The HINO engine, (a subsidiary of Toyota) establishes a reputation for low fuel consumption and environmental performance. This machine adopts this engine and KOBELCO fine tunes the match between the engine and hydraulic systems for the optimum combination of efficiency, operability, and environmental conscientiousness.



### PM emissions cut: Limits creation of particulate matter (which results from incomplete combustion of fuel)

- Common rail system**  
High-pressure injection atomizes the fuel, and injection timing is more precise, improving combustion efficiency.
- VG turbo**  
The opening of the exhaust side nozzles in the variable-geometry turbocharger adjusts air intake to maximize combustion efficiency. At low engine speeds the nozzles are closed, then the turbo speed is increased and air intake is boosted. This helps lower fuel consumption.
- Diesel Particulate Filter (DPF)**  
Carbon is built up as soot on the diesel particulate filter and is burned off at high temperature. No Exhaust fluid required. The system allows for manual or automatic filter regeneration.

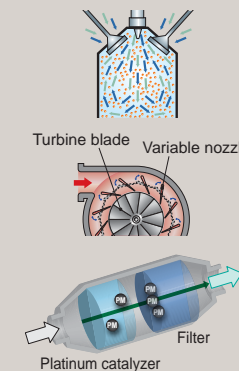

### NOx emissions cut: Reduces nitrogen oxides (created by reaction with oxygen at high temperature)

- EGR cooler**  
While ensuring sufficient oxygen for combustion, cooled exhaust gases are mixed with the air intake and re-circulated into the engine. Then the oxygen concentration is lowered and the combustion temperature is lowered.

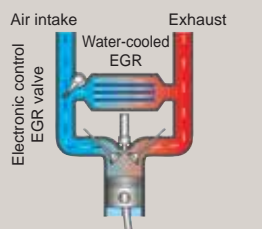

## Color Multi-Display

The easy-to-read liquid crystal color multi-display, which has vivid colors and graphical indications, is provided within the new type console.



- The instantly understandable analogue gauge for fuel level and engine coolant temperature.
- The green indicator lights on at the low fuel consumption operation.
- The display can be switched between the fuel consumption graph or the view of the rear view visibility monitoring camera.
- All switches such as the work mode select switch are conveniently gathered here.

# Designed from the Operator's Point of View

## Comfortability

### Big Cab

The "Big cab" provides a roomy operating space with plenty of legroom, and the door opens wide for entry and exit. As well as giving a wide, open view to the front, the cab has increased window areas on both sides and to the rear, for improved visibility in all directions.



### Excellent Visibility

Eliminating the right-side cab support to make a single window has improved visibility to the right.

- Eliminating the right-side cab support to make a single window has improved wide visibility.
- The view is not obstructed by the provided rise up wiper when the wiper is not used.
- Safety check is easy with the left and right rearview mirrors, right lower mirror, and rearward visibility monitoring camera.
- The tempered green glass complied with European Standards is adopted.

## Safety

### ROPS Cab

The newly developed, ROPS (Roll-Over -Protective Structure)-compliant cab clears ISO standards(ISO-12117 -2: 2008) and ensures greater safety for the operator.



- FOPS guard (Meets or exceeds current OHSA standards)



- Level 2 FOPS Guard (ISO 10262) is equipped as standard.
- To fit vandalism guards or front rock guards, please contact your KOBELCO dealer. (Mounting brackets for vandalism guards provided standard)

### Wide-Access Cab Helps Smooth Entry and Exit

Easy entry and exit assured with wider cab entry and safety lock lever integrated with mounting for control levers.



### Comfortable Operating Environment

The inside of the cab is fully equipped for operator comfort. For example, the seat has many adjustment points for operating the machine and also when relaxing in the cab. A larger storage space is provided. Operator comfort was the first priority in mind when designing the cab.



Reclining seat



Double slide seat



Powerful automatic air conditioner



Two-speaker FM/AM radio with station select



Large cup holder



Spacious luggage tray

### Rear View Camera

A rear view camera is installed as standard equipment to simplify checking for rear view behind the machine. The brilliant color picture appears on the LCD monitor.



### Safety Features That Take Various Scenarios into Consideration



- Protective panel separates the pump compartment from the engine



- Swing flashers / rear working lights



- Hammer for emergency exit

- Hand rails are complied with European Standards
- Thermal guard prevents contact with hot components during engine inspections
- Travel alarm
- Retractable seatbelt requires no manual adjustment

# The Value and Quality of Sturdy Construction!



## Attachment and frame structures are designed for maximum durability

The use of forgings and castings in and around the front attachments minimizes stress concentrations in the Kobelco standard Heavy Duty Booms and arms. The side frames and car body structures are also optimized for heavy duty service and long life via the use of thicker axles at the side frame attachment and a heavy cross section of the complete structure.

## Quality of Durability

The high quality urethane paint is applied to the machine body to keep the machine body beautiful for a long time. The bolt on handrail is attached to the cab for an easy repair and a special high durability seat covering is used for long life and cool operation on the operator's seat.



## 500 Hour Attachment Lubrication Interval

The self lubrication bushings are used at the attachment pins and the bushings with high abrasion resistant property are used at the pins around the bucket. The lubrication cycle of the lubrication points around the bucket is 250 hours and that of other lubrication points is 500 hours.



## New-Design Fuel Filter Catches 95% of Dust and Impurities

The large-capacity fuel filter is designed specifically for common rail engines. With an increased filtering performance, this high-grade filter catches 95% of all dust particles and other impurities in the fuel.



## Track Guides Installed in Three Places

Three heavy duty track guides, on each crawler side frame are installed as standard equipment. This assures track stability in the most demanding situations.



## Long-Life Hydraulic Oil Reduces Replacement Costs

The long-life hydraulic oil features a base oil with excellent demulsification, with optimized wear-resistant additives and antioxidants that help to boost the service life to 5,000 hours and greatly reduces the number of changes necessary.

Long-life hydraulic oil  
5,000 hours

## Highly Durable Super-fine Filter (Hydraulic oil filter)

The high-capacity hydraulic oil filter incorporates glass fiber with superior cleaning power and durability. With a replacement interval of 1,000 hours and a construction that allows replacement of the filter element only, it is both highly effective and highly economical.



Super-fine filter

## Double-Element Air Cleaner as Standard

The large-capacity element features a double-filter structure that keeps the engine running clean even in dusty environments.



## Potentiometer for Emergency Mode and Controls Permits Continued Operation in the Unlikely Event of Malfunction



If unexpected trouble is experienced with the ITCS mechatronic control system, the machine can still be operated using the emergency acceleration system. Digging modes are also automatically relayed to an emergency system so that digging can continue with minimum down time.

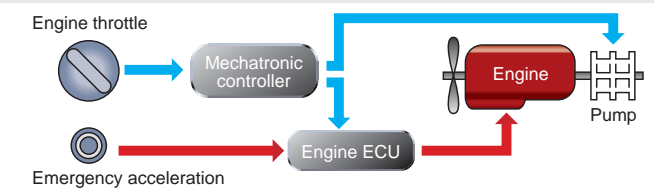

## Newly designed MCU (Memory Control Unit)



New MCU

Conventional MCU

- Vertical alignment and sealed cover gives better protection from water and dust
- Integration in base plate boosts assembly quality
- Reliable fixture to base plate

## Countermeasures Against Electrical System Failure

All elements of the electrical system, including the controller, are mounted INSIDE the cab for increased reliability.

# Fast, Accurate and Low-Cost Maintenance



## Machine Information Display Function Is Essential for Accurate Maintenance

- When necessary, only the maintenance required item is displayed by the maintenance information display function.
- Malfunction at the electrical system is detected and displayed in the early stage by the self-diagnostic function.
- The machine condition can be easily checked by the service diagnosis function.
- Malfunction including irregular and transient one can be checked by the trouble history record function.



- Engine Oil Exchange
- Fuel Filter Exchange
- Hydraulic Oil Filter Exchange
- Hydraulic Oil Exchange

## Maintenance from the Ground with Comfortable Working Posture

The components and parts those are subjected to be checked in daily inspection and periodic maintenance are provided at the accessible positions from the ground. This machine is designed with easy inspection and maintenance in mind.

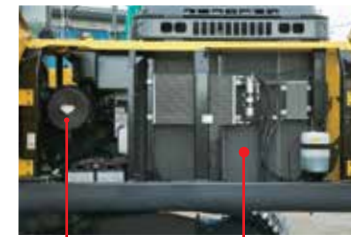

Air Cleaner (double element) Radiator



Fuel Filter (with built-in water separator) Engine Oil Filter



Handrails



Front mounted three steps instead of only two for easy safe access.

## Easy-to-Access Inside Cab Helps Easy Inspection



Easy-access fuse box.



DPF Manual Regeneration Switch



Hour meter can be checked while standing on the ground.



Air conditioner filter can be easily removed without tools for cleaning. One for outside air and one for inside air.

## Easy-to-Clean Parts Shorten the Cleaning Time



Special sloped crawler side frame design is easily cleaned of mud.



Detachable two-piece floor mat with handles for easy removal.



Fuel tank drain valve.

## Total Support for Machines with Network Speed and Accuracy

Our "KOMEX" allows you to use the Internet to manage information from your office for machines operating in all areas. Be prepared for any problems with strategic information and cost management. This provides a wide range of support for your business operations.

### Direct Access to Operational Status

#### Location Data

Accurate location data can be obtained even from sites where communications are difficult.

#### Operating Hours

A comparison of operating times of machines at multiple locations shows which locations are busier and more profitable. Operating hours on site can be accurately recorded, for running time calculations needed for rental machines, etc.

#### Fuel Consumption Data

Data on fuel consumption and idling times can be used to indicate improvements in fuel consumption.

#### Graph of Work Content

The graph shows how working hours are divided among different operating categories, including digging, idling, traveling, and optional operations (N&B).

#### Graph of Machine Duty Cycles



### Maintenance Data and Warning Alerts

#### Machine Maintenance Data

Provides maintenance status of separate machines operating at multiple sites. Maintenance data is also relayed to KOBELCO service personnel, for more efficient planning of periodic servicing.

### Security System

#### Engine Start Alarm

The system can be set an alarm if the machine is operated outside the designated time.

#### Area Alarm

It can be set an alarm if the machine is moved out of its designated area to another location.

## Engine

Model	HINO J08E-UV
Type:	Direct injection, water-cooled, 4-cycle diesel engine with turbocharger, intercooler (Complies with EU (NRMM) Stage IIIB, EPA Interim Tier IV, and act on regulation, etc. of emission from non- road special motor vehicles (Japan))
No. of cylinders:	6
Bore and stroke:	4.41" (112 mm) x 5.12" (130 mm)
Displacement:	469 cu.in (7.684 L)
Rated power output:	270hp {201 kW} / 2,100 rpm (SAE NET)
Max. torque:	736 lb-ft {998 N·m} / 1,600 rpm (SAE NET)

## Hydraulic System

Pump	
Type:	Two variable displacement pumps + 1 gear pump
Max. discharge flow:	2 x 77.7 U.S.gph {2 x 294 L/min}, 1 x 5.3 U.S.gph {1 x 20 L/min}
Relief valve setting	
Boom, arm and bucket:	4,970 psi {34.3 Mpa}
Power Boost:	5,480 psi {37.8 Mpa}
Travel circuit:	4,970 psi {34.3 Mpa}
Swing circuit:	4,210 psi {29.0 Mpa}
Control circuit:	725 psi {5.0 Mpa}
Pilot control pump:	Gear type
Main control valves:	8-spool
Oil cooler:	Air cooled type

## Swing System

Swing motor:	Axial piston motor
Parking brake:	Oil disc brake, hydraulic operated automatically
Swing speed:	10.0 rpm
Swing torque:	88,500 lb-ft {120 kN·m} (SAE)
Tail swing radius:	11'6" {3,500 mm}
Min. front swing radius:	14'4" {4,370 mm}

## Attachments

Backhoe bucket and arm combination

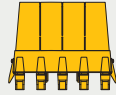
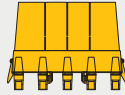
Use	Backhoe bucket			
				
Bucket capacity	SAE heaped cu.yd.{m³}	1.57 {1.2}	1.83 {1.40}	2.09 {1.60}
	SAE Struck cu.yd.{m³}	1.10 {0.84}	1.31 {1.00}	1.57 {1.20}
Opening width	With side cutter inches {mm}	49 {1,240}	56 {1,420}	62 {1,570}
	Without side cutter inches {mm}	44 {1,110}	55 {1,390}	57 {1,450}
No. of bucket teeth		4	5	5
Bucket weight	lbs {kg}	2,050 {930}	2,380 {1,080}	2,510 {1,140}
Combinations	8'6" {2.6 m} short arm	○	○	⊙
	10'10" {3.3 m} standard arm	○	⊙	△
	13'7" {4.15 m} long arm	○	△	×

○ Standard ○ Recommended △ Loading only × Not recommended

## Travel System

Travel motors:	2 x axial piston, two-speed motors
Parking brakes:	Oil disc brake per motor
Travel shoes:	48 each side
Travel speed:	3.5 / 2.0 mph {5.6 / 3.3 km/h}
Drawbar pulling force:	72,200 lbs {321 kN} (SAE J 1309)
Gradeability:	70 % {35°}
Ground clearance:	19.7" (500 mm)

## Cab & Control

Cab	
All-weather, sound-suppressed steel cab mounted on the silicon-sealed viscous mounts and equipped with a heavy, insulated floor mat.	
Control	
Two hand levers and two foot pedals for travel	
Two hand levers for excavating and swing	
Electric rotary-type engine throttle	

## Boom, Arm & Bucket

Boom cylinder:	5.5" {140 mm} x 5'1" {1,550 mm}
Arm cylinder:	6.7" {170 mm} x 5'10" {1,788 mm}
Bucket cylinder:	5.9" {150 mm} x 3'11" {1,193 mm}

## Refilling Capacities & Lubrications

Fuel tank:	153.2 U.S.gal {580 L}
Cooling system:	7.6 U.S.gal {28.9 L}
Engine oil:	7.5 U.S.gal {28.5 L}
Travel reduction gear:	2 x 2.5 U.S.gal {2 x 9.5 L}
Swing reduction gear:	2.0 U.S.gal {7.4 L}
Hydraulic oil tank:	64.7 U.S.gal {245 L} tank oil level 109.1 U.S.gal {413 L} hydraulic system

## Working Ranges

Unit: ft-in {m}

Range	Boom	21'4" {6.50m}		
		Short 8'6" {2.6 m}	Standard 10'10" {3.30 m}	Long 13'7" {4.15 m}
a- Max. digging reach		34'10" {10.61}	36'11" {11.26}	39'3" {11.97}
b- Max. digging reach at ground level		34'1" {10.40}	36'3" {11.06}	38'8" {11.79}
c- Max. digging depth		22'6" {6.86}	24'10" {7.56}	27'7" {8.41}
d- Max. digging height		33'8" {10.26}	34'9" {10.58}	35'1" {10.70}
e- Max. dumping clearance		23'2" {7.06}	24'2" {7.37}	24'8" {7.53}
f- Min. dumping clearance		10'11" {3.32}	8'7" {2.62}	5'10" {1.77}
g- Max. vertical wall digging depth		19'2" {5.84}	21'8" {6.61}	23'5" {7.15}
h- Min. swing radius		14'7" {4.45}	14'4" {4.37}	14'6" {4.43}
i - Horizontal digging stroke at ground level		21'11" {6.67}	19'1" {5.82}	27'2" {8.27}
j - Digging depth for 8 feet flat bottom		13'10" {4.21}	24'3" {7.40}	28'8" {7.21}
Bucket capacity SAE heaped cu.yd.{m³}		2.09 {1.60}	1.83 {1.40}	1.57 {1.20}

## Digging Force

Unit: lbs {kN}

Arm length	21'4" {6.50m}			
	Short 8'6" {2.6 m}	Standard 10'10" {3.30 m}	Long 13'7" {4.15 m}	
Bucket digging force	SAE	45,954 {204}	45,954 {204}	45,954 {204}
	ISO	50,582 {225}*	50,582 {225}*	50,582 {225}*
Arm crowding force	SAE	44,500 {198}	37,100 {160}	30,800 {137}
	ISO	49,000 {218}*	39,600 {176}*	33,700 {150}*
		46,100 {205}	37,100 {165}	31,500 {140}
		50,600 {225}*	40,700 {181}*	34,600 {154}*

\* Power Boost engaged.

## Dimensions

Arm length	Short 8'6" {2.6 m}	Standard 10'10" {3.30m}	Long 13'7" {4.15 m}
A Overall length	37'1" {11,300}	36'9" {11,200}	36'9" {11,200}
B Overall height (to top of boom)	11'11" {3,640}	11'3" {3,420}	11'9" {3,590}
C Overall width	11'1" {3,390}**		
D Overall height (to top of cab)	10'6" {3,210}		
E Ground clearance of rear end*	3'11" {1,190}		
F Ground clearance*	19.7" {500}		

Unit: ft-in{mm}	
G Tail swing radius	11'6" {3,500}
G' Distance from center of swing to rear end	11'6" {3,500}
H Tumbler distance	13'3" {4,050}
I Overall length of crawler	16'3" {4,960}
J Track gauge	8'6" {2,590}
K Shoe width	23.6" {600} / 27.6" {700} / 31.5" {800} / 35.4" {900}
L Overall width of upperstructure	9'9" {2,980}

\* Without including height of shoe lug  
\*\* Shoe width : 31.5" {800mm}

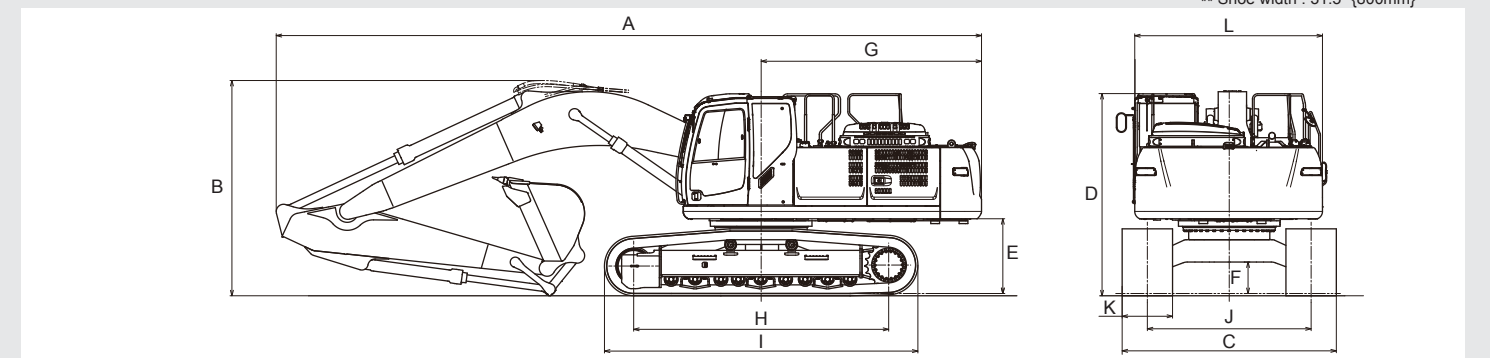

## Operating Weight & Ground Pressure

In standard trim, with standard boom, 10'10" {3.30m} arm, and 1.83 cu.yd. {0.83m³} SAE heaped bucket

Shaped	Triple grouser shoes (even height)				
Shoe width	ft-in{mm}	23.6" {600}	27.6" {700}	31.5" {800}	35.4" {900}
Overall width of crawler	ft-in{mm}	10'6" {3,190}	10'10" {3,290}	11'1" {3,390}	11'5" {3,490}
Ground pressure	psi {kPa}	9.7 {67}	8.4 {58}	7.5 {52}	6.7 {46}
Operating weight	lbs {kg}	78,500 {35,600}	80,000 {36,300}	80,900 {36,700}	81,800 {37,100}

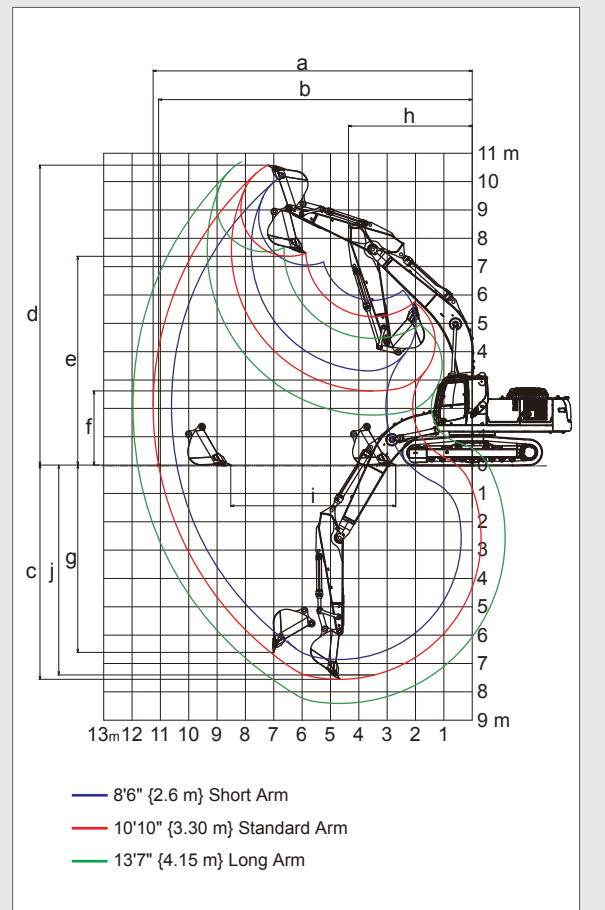

— 8'6" {2.6 m} Short Arm  
— 10'10" {3.30 m} Standard Arm  
— 13'7" {4.15 m} Long Arm

## Lifting Capacities

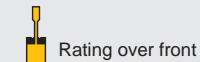
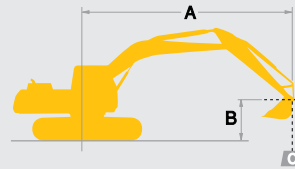

Rating over front

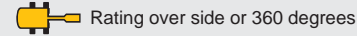

Rating over side or 360 degrees

A – Reach from swing centerline for bucket hook  
B – Bucket hook height above/below ground  
C – Lifting capacities in pounds

SK350LC		Standard Arm: 10'10" {3.30m} Bucket: 1.83cu.yd. {1.40m <sup>3</sup> } SAE heaped 2,380lbs {1,080kg} Shoe: 31'5" {800mm} <b>HEAVY LIFT</b>																
		A		5' {1.5m}		10' {3.0m}		15' {4.6m}		20' {6.1m}		25' {7.6m}		30' {9.1m}		At Max. Reach		Radius
B																		
25' {7.6m}	lb(kg)																	
20' {6.1m}	lb(kg)																	
15' {4.6m}	lb(kg)																	
10' {3.0m}	lb(kg)																	
5' {1.5m}	lb(kg)																	
G.L.	lb(kg)																	
-5' {-1.5m}	lb(kg)																	
-10' {-3.0m}	lb(kg)																	
-15' {-4.6m}	lb(kg)																	
-20' {-6.1m}	lb(kg)																	

SK350LC		Short Arm: 8'6" {2.60m} Bucket: 2.09 cu.yd. {1.60 m <sup>3</sup> } SAE heaped 2,510lbs {1,140kg} Shoe: 31'5" {800 mm} <b>HEAVY LIFT</b>												
		A		10' {3.0m}		15' {4.6m}		20' {6.1m}		25' {7.6m}		At Max. Reach		Radius
B														
25' {7.6m}	lb(kg)													
20' {6.1m}	lb(kg)													
15' {4.6m}	lb(kg)													
10' {3.0m}	lb(kg)													
5' {1.5m}	lb(kg)													
G.L.	lb(kg)													
-5' {-1.5m}	lb(kg)													
-10' {-3.0m}	lb(kg)													
-15' {-4.6m}	lb(kg)													

SK350LC		Long Arm: 13'7" {4.15m} Bucket: 1.57 cu.yd. {1.20m <sup>3</sup> } SAE heaped 2,050lbs {930kg} Shoe: 31'5" {800mm} <b>HEAVY LIFT</b>																
		A		5' {1.5m}		10' {3.0m}		15' {4.6m}		20' {6.1m}		25' {7.6m}		30' {9.1m}		At Max. Reach		Radius
B																		
25' {7.6m}	lb(kg)																	
20' {6.1m}	lb(kg)																	
15' {4.6m}	lb(kg)																	
10' {3.0m}	lb(kg)																	
5' {1.5m}	lb(kg)																	
G.L.	lb(kg)																	
-5' {-1.5m}	lb(kg)																	
-10' {-3.0m}	lb(kg)																	
-15' {-4.6m}	lb(kg)																	
-20' {-6.1m}	lb(kg)																	

### Notes:

- Do not attempt to lift or hold any load that is greater than these lift capacities at their specified lift point radius and heights. Weight of all accessories must be deducted from the above lift capacities.
- Lift capacities are based on machine standing on level, firm, and uniform ground. User must make allowance for job conditions such as soft or uneven ground, out of level conditions, side loads, sudden stopping of loads, hazardous conditions, experience of personnel, etc.
- Bucket lift hook is defined as lift point.
- The above lifting capacities are in compliance with SAE J/ISO 10567. They do not exceed 87 % of hydraulic lifting capacity or 75 % of tipping load. Lifting capacities marked with an asterisk (\*) are limited by hydraulic capacity rather than tipping load.
- Operator should be fully acquainted with the Operator's and Maintenance Instructions before operating this machine. Rules for safe operation of equipment should be adhered to at all times.
- Lift capacities apply to only machines as originally manufactured and normally equipped by KOBELCO CONSTRUCTION MACHINERY CO., LTD.

## Standard Equipment

### ENGINE

- Engine, HINO J08E-UV, Diesel engine with turbocharger and intercooler, Tier 4 interim certified
- Automatic engine deceleration
- Batteries (2 x 12V - 96Ah)
- Starting motor (24V - 5 kW), 60 amp alternator
- Removable clean-out screen for radiator
- Automatic engine shut-down for low engine oil pressure
- Engine oil pan drain cock
- Double element air cleaner

### CONTROL

- Working mode selector (H-mode, S-mode and ECO-mode)
- Heavy Lift and Power Boost "without time limit"

### SWING SYSTEM & TRAVEL SYSTEM

- Swing rebound prevention system
- Straight propel system
- Two-speed travel with automatic down shift
- Sealed & lubricated track links
- 31.5" {800mm} track shoes
- Grease-type track adjusters
- Automatic swing brake
- Lower track guards

### HYDRAULIC

- Arm regeneration system
- Auto warm up system
- Aluminum hydraulic oil cooler

### MIRRORS & LIGHTS

- Three rearview mirrors and rearview camera
- Two front working lights
- Swing flashers

## Optional Equipment

- Wide range of shoes
- Boom & arm load (lock) holding valve
- Front-guard protective structures
- Additional hydraulic circuit

### CAB & CONTROL

- ROPS cab
- Two control levers, pilot-operated
- Horn, electric
- Integrated left-right slide-type control box
- Cab, all-weather sound suppressed type
- Ashtray
- Cigarette lighter
- Cab light (interior)
- Coat hook
- Luggage tray
- Large cup holder
- Detachable two-piece floor mat
- 7-way adjustable suspension seat
- Retractable seatbelt
- Headrest
- Handrails
- Heater and defroster
- Intermittent windshield wiper with double-spray washer
- Skylight
- Top guard
- Tinted safety glass
- Pull-type front window and removable lower front window
- Easy-to-read multi-display monitor
- Automatic air conditioner
- Emergency escape hammer
- Radio, AM/FM Stereo with speakers
- Travel alarm
- Drain pressure switch
- DPF regeneration switch
- 12V converter
- Control pattern changer (2-way)