

**STANDARD EQUIPMENT**

**ENGINE**

- Engine, MITSUBISHI D04FR-74kW-01, Diesel engine with turbocharger and intercooler, Tier 4 interim certified
- Automatic engine deceleration
- Batteries (2 x12V - 80 Ah)
- Starting motor (24 V - 5kW), 50 amp alternator
- Automatic engine low idle for low engine oil pressure
- Engine oil pan drain cock
- Double element air cleaner

**CONTROL**

- Working mode selector (H-mode, S-mode and ECO-mode)

**SWING SYSTEM & TRAVEL SYSTEM**

- Swing rebound prevention system
- Straight propel system
- Two-speed travel with automatic down shift
- Sealed & lubricated track links
- 23.6" (600mm) track shoes
- Grease-type track adjusters
- Automatic swing brake

**MIRRORS & LIGHTS**

- Three rear view mirrors and rearview camera
- Two front working lights
- Swing flashers

**CAB & CONTROL**

- Two control levers, pilot-operated
- Horn, electric
- Integrated left-right slide-type control box
- Ashtray
- Cab light (interior)
- Coat hook
- Large cup holder
- Detachable two-piece floor mat
- 7-way adjustable suspension seat
- Retractable seatbelt
- Headrest
- Handrails
- Heater and defroster
- Intermittent windshield wiper with double-spray washer
- Sky light
- Top guard
- Tinted safety glass
- Pull-type front window and removable lower front window
- Easy-to-read multi-display monitor
- Automatic air conditioner
- Emergency escape hammer
- Radio, AM/FM Stereo with speakers
- Travel alarm
- Drain pressure switch
- DPF regeneration switch
- 12V converter

**OPTIONAL EQUIPMENT**

- Boom & arm load (lock) holding valve
- Front-guard protective structures (May interfere with bucket rotation)
- Additional hydraulic circuit
- Control pattern changer (2-way)
- Cab additional light
- Rain visor (may interfere with bucket action)
- Add-on type counterweight (+580kg)

Note: Standard and optional equipment may vary. Consulty our KOBELCO dealer for specifics.

Note: This catalog may contain attachments and optional equipment that are not available in your area. It may also contain photographs of machines with specifications that differ from those of machines sold in your area. Please consult your nearest KOBELCO distributor for those items you require. Due to our policy of continuous product improvements all designs and specifications are subject to change without advance notice. Copyright by **KOBELCO CONSTRUCTION MACHINERY CO., LTD.** No part of this catalog may be reproduced in any manner without notice.

**KOBELCO CONSTRUCTION MACHINERY U.S.A. INC.**

4690 World Houston Parkway Houston, TX 77032  
http://www.kobelco-usa.com/

Inquiries To:

Bulletin No. SK140SRLC-NA-201

2013080000E Printed in USA

**Hydraulic Excavators**

**SK 140SR<sup>LC</sup>**

- **Bucket Capacity :**  
0.50 cu.yd. (0.38 m<sup>3</sup>) SAE heaped
- **Engine Power :**  
92.8 hp (69.2kW) / 2,000 rpm (SAE NET)
- **Operating Weight :**  
33,100 lb (14,100 kg)



*Complies with the latest exhaust emission regulations*



US EPA  
Interim Tier IV



EU (NRMM)  
Stage III B



Japanese  
Regulations

**DRIVEN BY  
PASSION**

# Fuel Consumption Gives You the Competitive Edge

KOBELCO's SR hydraulic excavator has undergone a new evolution.

KOBELCO installed its full range of fuel-saving technologies in this SR model, resulting in unmatched low fuel consumption that provides a class leading standard of efficiency for engine-driven hydraulic excavators.

Outstanding performance in tight spaces, on-site safety, less stress for the operator KOBELCO was first to understand these demands and in response developed SR, short rear swing, excavators. The acclaimed SR concept went on to be adopted throughout the industry.

But KOBELCO didn't stop there. Aware of changing needs among machine users in a changing social environment, KOBELCO has taken the SR concept through a further evolution with value-added features.

KOBELCO's unique design for engine cooling, the iNDR system, cuts noise to extremely low levels.

The newest KOBELCO approach to low fuel consumption, NEXT-3E, now also applies to short rear swing models which maximize work volumes while saving on fuel. And the new ECO-mode in the SK140SRLC creates even greater savings on fuel to turn SR models into exceptional high-earning machines.

KOBELCO continues to lead the field in short rear swing excavators.

## Five Ways the SK140SRLC Scores:

- Low Noise: iNDR
- More Work with Less Fuel!
- Efficient Performance!
- Fast, Accurate and Low-Cost Maintenance
- A Working Environment that Helps Operator Concentrate on the Job



NEXT-3E



Pursuing the "Three E's"  
The Perfection of  
Next-Generation,  
Network Performance

Enhancement  
Greater Performance Capacity

Economy  
Improved Cost Efficiency

Environment  
Features That Go Easy on the Earth

## The Revolutionary Integrated Noise and Dust Reduction Cooling System

iNDR

KOBELCO's exclusive iNDR Cooling System delivers amazingly quiet operation.

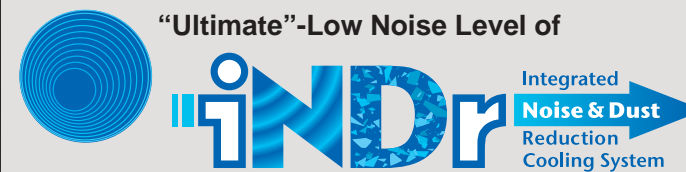

### The iNDR revolution



#### ● Concept

KOBELCO has developed the revolutionary integrated Noise and Dust Reduction Cooling System, with the engine compartment placed inside a single duct that connects the air intake to the exhaust outlet.



#### ● Reduces Noise

The intake and exhaust are offset, with the holes and joints in the sections corresponding to the duct wall completely covered to reduce noise at the intake and exhaust apertures. This design, coupled with the generous use of insulation-material inside the duct, minimizes engine noise.

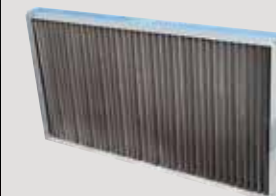

#### ● Reduces Dust

The high-performance iNDR filter removes dust from the intake air, ensuring a quieter, cleaner engine and keeps the cooling unit free of clogging so that no regular cleaning is necessary.

## More Work with Less Fuel!

### Fuel Consumption and Work Volume

The new hydraulic system and an additional ECO-mode have cut fuel consumption by up to 21%.

**H-mode** (vs previous SK140SR<sub>LC</sub> in H-mode)

Fuel consumption (L/h)

**8%** decrease

Work volume per liter of fuel (m<sup>3</sup>/L)

**10%** increase

**S-mode** (vs previous SK140SR<sub>LC</sub> in H-mode)

Fuel consumption (L/h)

**16%** decrease

Work volume per liter of fuel (m<sup>3</sup>/L)

**19%** increase

**ECO-mode** (vs previous SK140SR<sub>LC</sub> in S-mode)

Great leap forward in energy-saving performance

Fuel consumption (L/h)

**22%** decrease

Work volume per liter of fuel (m<sup>3</sup>/L)

**19%** increase

\* Figures for fuel consumption: fuel consumed per hour (L/h) compared with previous model, in KOBELCO tests.

\* Figures for work volume: digging volume per liter of fuel (m<sup>3</sup>/L) compared with previous model, in KOBELCO tests.

### ECO-mode

Work modes for a closer match to the job at hand. An addition to the existing H-mode and S-mode, the new ECO-mode saves even more energy.



**H-mode:** For heavy duty operation, when a higher performance level is required.

**S-mode:** For normal operations with lower fuel consumption.

**ECO-mode:** Puts priority on low fuel consumption and economic performance.

### Significant Extension of Continuous Working Hours

The combination of a large-capacity fuel tank and excellent fuel efficiency delivers an impressive increase in the length of continuous usage.

Fuel tank capacity:  
**52.8 U.S.gal**  
**(200 L)**

### NEXT-3E Technology New Hydraulic System

Rigorous inspections for pressure loss are performed on all components of the hydraulic piping, from the spool of control valve to the connectors. This regimen, combine with the use of a new, high-efficiency pump, cuts energy loss to a minimum.

### NEXT-3E Technology Total Tuning Through Advanced ITCS Control

The next-generation engine control is governed by a new version of ITCS, which responds quickly to sudden changes in hydraulic load to ensure that the engine runs as efficiently as possible with a minimum of wasted output.

**ITCS** ITCS (Intelligent Total Control System) is an advanced, computerized system that provides comprehensive control of all machine functions.

### NEXT-3E Technology Next-Generation Electronic Engine Control

The high-pressure, common-rail fuel-injection engine with the multiple injection system features adjustable control to maximize fuel efficiency and provide powerful low-speed torque. The result is a highly fuel-efficient engine.



### Tier4 compliant engine (No Exhaust fluid required)

**PM emissions cut:** Limits creation of particulate matter (which results from incomplete combustion of fuel)

■ **Common rail system**  
High-pressure injection atomizes the fuel, and injection timing is more precise, improving combustion efficiency.

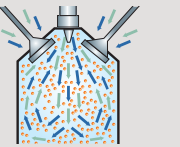

■ **Diesel Particulate Filter (DPF)**  
Carbon is built up as soot on the diesel particulate filter and is burned off at high temperature. No Exhaust fluid required. The system allows manual or automatic filter regeneration.

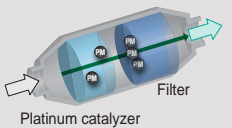

**NOx emissions cut:** Reduces nitrogen oxides (created by reaction with oxygen at high temperature)

■ **EGR cooler**  
While ensuring sufficient oxygen for combustion, cooled exhaust gases are mixed with the air intake and re-circulated into the engine. Then the oxygen concentration is lowered and the combustion temperature is lowered.

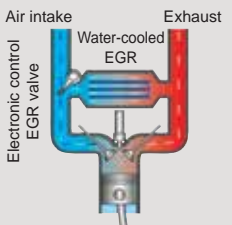

### Automatic Acceleration / Deceleration Function Reduces Engine Speed

Engine speed is automatically reduced when the control lever is placed in neutral, effectively saving fuel and reducing noise and exhaust emissions. The engine quickly returns to the previous speed when the lever is moved out of neutral.

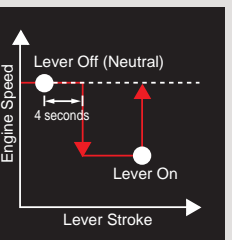

Photos in this catalog are the machine with the option installed.

## Efficient Performance!

### Top-Class Powerful Digging

For more efficient work performance.  
(SAE J1179:1990)

Max. arm crowding force: **18,100lbs {80.3kN}**

Max. bucket digging force: **12,700lbs {56.7kN}**

### Powerful Travel

Drawbar pulling force: **31,100lbs {139kN}**

### Great Swing Power, Short Cycle Times

Powerful swing power and top-class swing speed.

Swing speed: **11.0rpm**

### Optional N&B (crusher and breaker)

The operator selects the desired mode from inside the cab, and the selector valve automatically configures the machine accordingly.

### Attachment Mode Selector Switch

There is a choice of three different attachment modes, to accommodate bucket, crusher, or breaker. The desired attachment mode can be selected with a switch, which automatically configures the selector valve. All attachment modes can be used in either S-mode or H-mode.



### Seamless, Smooth Combined Operations

The machines have inherited the various systems that make inching and combined operations easy and accurate, with further refinements that make a good thing even better. Leveling and other combined operations can be carried out with graceful ease.

- Electronic active control system
- Arm regeneration system
- Boom lowering regeneration system
- Variable swing priority system
- Swing rebound prevention system

### Excellent Working Ranges

Greater working ranges with class-topping vertical digging depth.

Max. digging height: **31'4" {9,560mm}**

Max. dumping height: **23'4" {7,100mm}**

Max. digging reach: **28'10" {8,780mm}**

Max. vertical digging depth: **17'10" {5,440mm}**

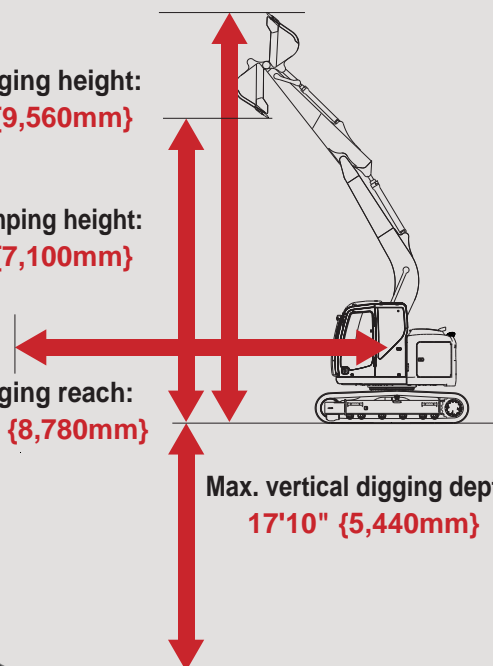

### Requires 12 ft. 9 in. of Working Space

The compact design allows the machine to perform continuous dig, 180 ° swing and dump operations within a working space of 12ft.9in".



Working radius equals the sum of the minimum front swing radius and tail swing radius. When the add-on type counterweight (+580 kg) is installed, the values of tail overhang and tail swing radius are increased.

### Mild Operating Sound

The iNDr cooling system also helps to keep the machine quiet, even at close quarters.

### Meets EMC(Electromagnetic Compatibility) Standards in Europe

Electrical shielding ensured that the machines clear all European standards and neither cause or are affected by electromagnetic interference.

# A Working Environment that Helps the Operator Concentrate on the Job at Hand!

## Big Cab



The "Big cab" provides a roomy operating space with plenty of legroom, and the door opens wide for entry and exit. As well as giving a wide, open view to the front, the cab has increased window areas on both sides and to the rear, for improved visibility in all directions.

## Excellent Visibility

Taking out the right-side cab support to make a single window has improved visibility to the right.



## Wide-Access Cab Aids Smooth Entry and Exit

Easy entry and exit assured with wider cab entry and safety lock lever integrated with mounting for control levers.



## Comfortable Operating Environment



● Double slide seat

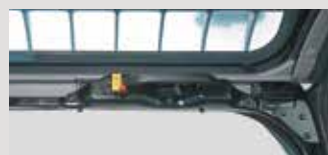

● One-touch lock release simplifies opening and closing front window



● Powerful automatic air conditioner



● Two-speaker FM/AM radio with station select



● Spacious luggage tray

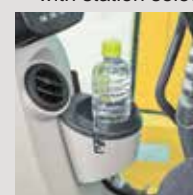

● Large cup holder

## Multi-Display Color Monitor

The LCD multi-display color monitor is fitted as standard. Operations data as well as the full range of machine-status data can readily be checked.

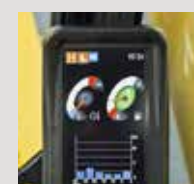

● Fuel consumption



● Maintenance



● Rearview monitoring

## ROPS Cab

The newly developed, ROPS (Roll-Over-Protective Structure)-compliant cab clears ISO standards (ISO-12117-2: 2008) and ensures greater safety for the operator.



- Level 2 FOPS Guard (ISO 10262) is equipped as standard.
- To fit vandalism guards, please contact your KOBELCO dealer. (Mounting brackets for vandalism guards provided standard)



- FOPS guard (Meets or exceeds current OSHA standards)

## Safety Features



- Protective panel separates the pump compartment from the engine



- Retractable seatbelt requires no manual adjustment



- Rear view camera



- Hammer for emergency exit

- Handrails meet European standards
- Thermal guard prevents contact with hot components during engine inspections
- Travel alarm
- Swing flasher

# Fast, Accurate and Low-Cost Maintenance

## Comfortable "On the Ground" Maintenance

All components that require regular maintenance are laid out for easy access with the control valves located on a single right-hand panel that opens and closes at a touch. In the pump compartment, there is remote access to such components as the engine oil filter and fuel filter (with built-in water separator). On the left side are the iNDr filter, air cleaner, radiator coolant, etc. Daily maintenance can be carried out easily without the need to climb up to the machine.

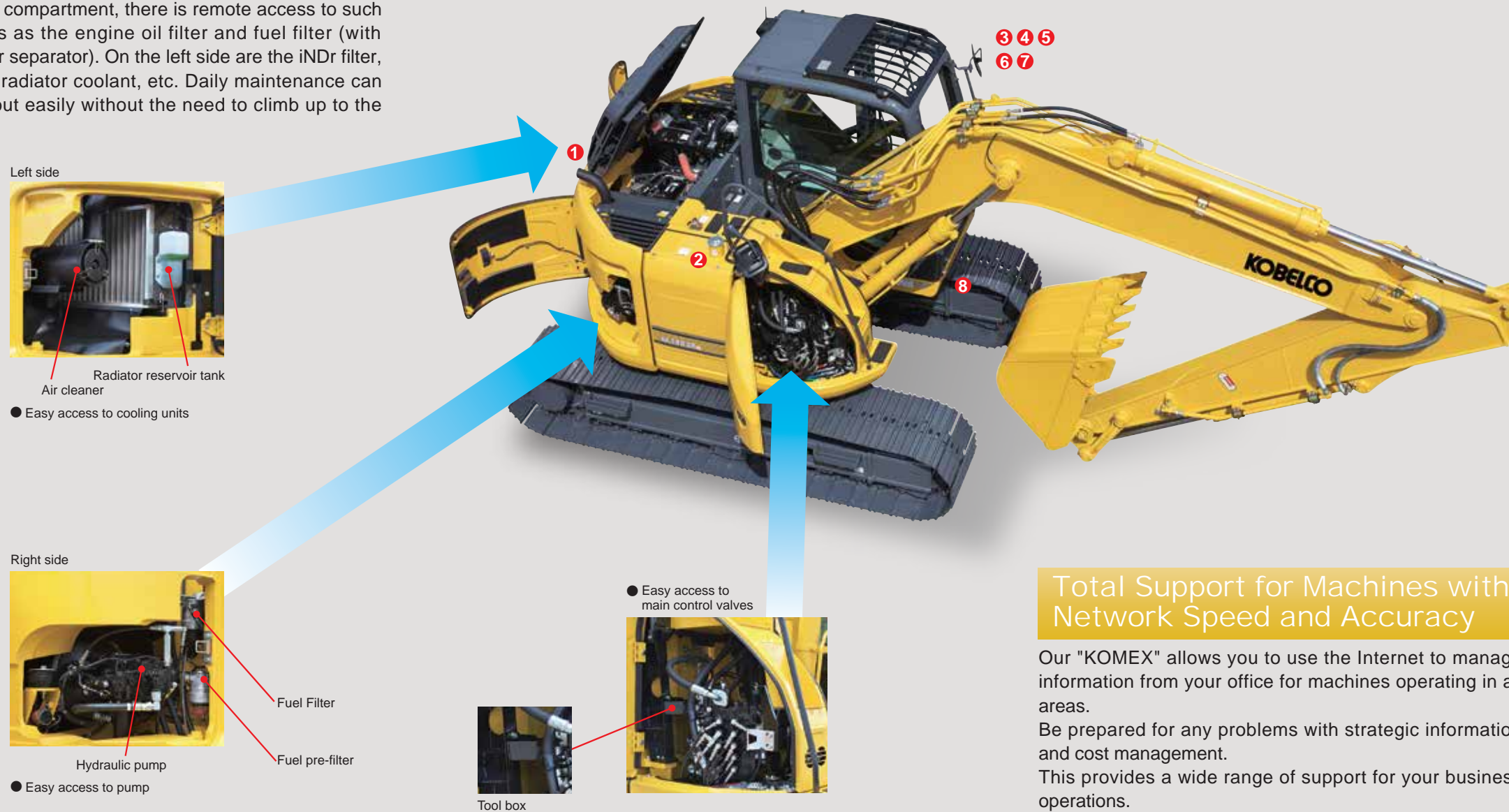

Left side  
Radiator reservoir tank  
Air cleaner  
● Easy access to cooling units

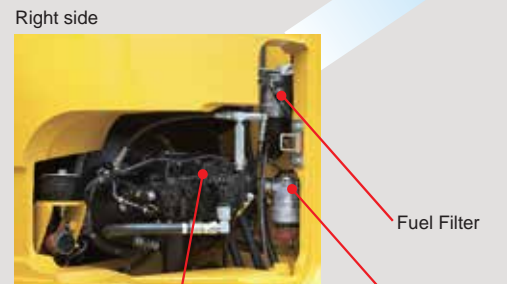

Right side  
Fuel Filter  
Fuel pre-filter  
Hydraulic pump  
● Easy access to pump

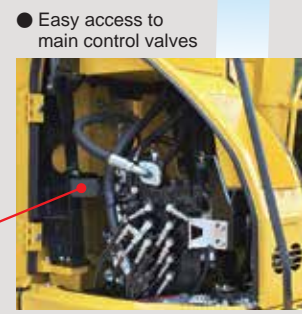

● Easy access to main control valves  
Tool box

## Fast Maintenance

- 1 Engine quick drain cock can be turned without tools.
- 2 Fuel tank equipped with bottom flange and large drain valve.
- 3 Hour meter can be checked while standing on the ground.
- 4 Easy-access fuse box. More finely differentiated fuses make it easier to locate malfunctions.
- 5 Washer fluid tank located under the cab floor mat.

## Easy Cleaning

- 6 Detachable two-piece floor mat with handles for easy removal. A floor drain located under floor mat.
- 7 Internal and external air conditioner filters can be easily removed without tools for cleaning.
- 8 Special crawler frame designed is easily cleaned of mud.

## Total Support for Machines with Network Speed and Accuracy

Our "KOMEX" allows you to use the Internet to manage information from your office for machines operating in all areas. Be prepared for any problems with strategic information and cost management. This provides a wide range of support for your business operations.

### Direct Access to Operational Status

- Location Data
- Operating Hours
- Fuel Consumption Data
- Graph of Work Content
- Graph of Machine Duty Cycles

### Maintenance Data and Warning Alerts

- Machine Maintenance Data

### Security System

- Engine Start Alarm
- Area Alarm

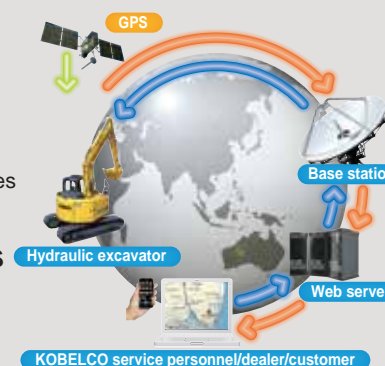

## iNDr Means Easy Maintenance

### iNDr Filter Blocks Out Dust



Outside air goes directly from the intake duct through the iNDr filter for dust removal. The filter features a 60-mesh screen, which means it has sixty holes per inch both vertically and horizontally, with a wide front surface area and accordion structure that resists clogging.

### Visual Checking and Easy Cleaning



When checking and cleaning the cooling system, one must deal with several cooling components like the radiator, oil cooler and intercooler, which all must be handled in different ways. But with the iNDr filter, there's just one filter in one place. If it looks dirty during start-up inspection, it can be cleaned easily and quickly.

## Long-Interval Maintenance

Long-life hydraulic oil reduces cost and labor.



## Super-fine Filter(Hydraulic oil filter)



High-performance, super-fine filter has a 1,000 hour replacement cycle.

## Double-Element Air Cleaner

The high-performance air cleaner has twice the capacity and service life of previous air cleaners and is installed behind the iNDr filter for even more effective cleaning performance.

## Monitor Display with Essential Information for Accurate Maintenance Checks

- Displays only the maintenance information that's needed, when it's needed.
- Self-diagnostic function that provides early-warning detection and display of electrical system malfunctions.
- Record function of previous technical issues including irregular and transient malfunction.



## Choice of 16 Languages for Monitoring Display

With messages including those requiring urgent action displayed in the local language, users in all parts of the world can work with greater peace of mind.



## Engine

Model	MITSUBISHI D04EG-74kW-01
<b>Type:</b>	Direct injection, water-cooled, 4-cycle diesel engine With turbocharger, intercooler
<b>No. of cylinders:</b>	4
<b>Bore and stroke:</b>	3.70" (94 mm) x 4.72" (120 mm)
<b>Displacement:</b>	203.3 cu.in. (3.331 L)
<b>Rated power output:</b>	92.8 hp (69.2kW) /2,000 rpm (SAE NET)
<b>Max. torque:</b>	265 lb-ft (359N·m) /1,600 rpm (SAE NET)



## Hydraulic System

Pump	
<b>Type:</b>	Two variable displacement pumps
<b>Max. discharge flow:</b>	2 x 34.3 U.S.gph {2 x 130L/min} , 1 x 5.3 U.S.gph {1 x 20L/min}
Relief valve setting	
<b>Boom, arm and bucket:</b>	4,970 psi {34.3 Mpa}
<b>Travel circuit:</b>	4,970 psi {34.3 Mpa}
<b>Swing circuit:</b>	4,060 psi {28.0 Mpa}
<b>Control circuit:</b>	725 psi {5.0 Mpa}
<b>Pilot control pump:</b>	Gear type
<b>Main control valves:</b>	12-spool
<b>Oil cooler:</b>	Air cooled type



## Swing System

<b>Swing motor:</b>	Axial piston motor
<b>Parking brake:</b>	Oil disc brake, hydraulic operated automatically
<b>Swing speed:</b>	11.0 rpm
<b>Swing torque:</b>	29,400 lb-ft {39.9 kN·m} (SAE)
<b>Tail swing radius:</b>	4'11" {1,490 mm}
<b>Min. front swing radius:</b>	7'10" {2,400 mm}



## Attachments

Backhoe bucket and arm combination

Use	Backhoe bucket							
	Normal digging							
<b>Bucket capacity</b>								
<b>SAE heaped</b>	0.31 {0.24}	0.41 {0.31}	0.50 {0.38}	0.59 {0.45}	0.65 {0.50}	0.75 {0.57}	0.90 {0.70}	
<b>Struck</b>	0.26 {0.20}	0.30 {0.23}	0.37 {0.28}	0.46 {0.35}	0.50 {0.38}	0.56 {0.43}	0.65 {0.50}	
<b>Opening width</b>								
<b>With side cutter</b>	23 {590}	28 {700}	31 {800}	36 {915}	39 {1,000}	43 {1,100}	—	
<b>Without side cutter</b>	20 {500}	24 {600}	28 {700}	31 {815}	35 {900}	39 {1,000}	45 {1,150}	
<b>No. of bucket teeth</b>	3	3	4	4	5	5	5	
<b>Bucket weight</b>	620 {280}	660 {300}	710 {320}	790 {360}	860 {390}	880 {400}	880 {400}	
<b>Combinations</b>								
<b>6'10" {2.09 m} arm</b>	○	○	○	○	○	○	○	△
<b>7'10" {2.38 m} arm</b>	○	○	○	○	○	○	○	—
<b>9'4" {2.84 m} arm</b>	○	○	○	○	○	○	○	—



## Travel System

<b>Travel motors:</b>	2 x axial piston, two-speed motors
<b>Parking brakes:</b>	Oil disc brake per motor
<b>Travel shoes:</b>	46 each side
<b>Travel speed:</b>	3.5 / 2.1 mph {5.6 / 3.4 km/h}
<b>Drawbar pulling force:</b>	31,100 lbs {139 kN} (SAE J 1309)
<b>Gradeability:</b>	70 % {35°}



## Cab & Control

Cab	
All-weather, sound-suppressed steel cab mounted on the silicon-sealed viscous mounts and equipped with a heavy, insulated floor mat.	
Control	
Two hand levers and two foot pedals for travel	
Two hand levers for excavating and swing	
Electric rotary-type engine throttle	



## Boom, Arm & Bucket

<b>Boom cylinder:</b>	3.9" {100 mm} x 3'7" {1,092 mm}
<b>Arm cylinder:</b>	4.5" {115 mm} x 3'8" {1,120 mm}
<b>Bucket cylinder:</b>	3.7" {95 mm} x 3'0" {903 mm}



## Dozer Blade (Optional)

<b>Dozer cylinder:</b>	4.3" {110 mm} x 8.7" {220 mm}
<b>Dimension:</b>	8'6" {2,590 mm} (width) x 1'11" {575 mm} (height)
<b>Working range:</b>	1'8" {500 mm} (up) x 1'11" {585 mm} (down)



## Refilling Capacities & Lubrications

<b>Fuel tank:</b>	52.8 U.S.gal {200 L}
<b>Cooling system:</b>	3.40 U.S.gal {13 L}
<b>Engine oil:</b>	3.04 U.S.gal {11.5 L}
<b>Travel reduction gear:</b>	2 x 0.55 U.S.gal {2 x 2.1 L}
<b>Swing reduction gear:</b>	0.44 U.S.gal {1.65 L}
<b>Hydraulic oil tank:</b>	22.5 U.S.gal {85.2 L} tank oil level 33.5 U.S.gal {126.7 L} hydraulic system



## Working Ranges

Unit: ft-in{m}

Range	Arm	15'4" {4.68m}	
		7'10" {2.38m}	9'4" {2.84m}
<b>a - Max. digging reach</b>		27'4" {8.34}	28'10" {8.78}
<b>b - Max. digging reach at ground level</b>		26'10" {8.19}	28'4" {8.64}
<b>c - Max. digging depth</b>		18'1" {5.52}	19'7" {5.98}
<b>d - Max. digging height</b>		30'2" {9.19}	31'4" {9.56}
<b>e - Max. dumping clearance</b>		22'1" {6.74}	23'4" {7.10}
<b>f - Min. dumping clearance</b>		8'6" {2.58}	7'3" {2.22}
<b>g - Max. vertical wall digging depth</b>		16'1" {4.89}	17'10" {5.44}
<b>h - Min. swing radius</b>		6'7" {2.00}	7'10" {2.40}
<b>i - Horizontal digging stroke at ground level</b>		13'10" {4.21}	15'5" {4.70}
<b>j - Digging depth for 8 feet flat bottom</b>		17'4" {5.29}	19'0" {5.79}
<b>Bucket capacity SAE heaped cu.yd. {m<sup>3</sup>}</b>		0.65 {0.50}	0.50 {0.38}

Unit: lbs {kN}

Digging Force	Arm length	7'10" {2.38m}	9'4" {2.84m}
		<b>Bucket digging force</b>	SAE 19,745 {87.8}
		ISO 20,255 {90.1}	21,357 {95.0}
<b>Arm crowding force</b>		SAE 14,006 {62.3}	12,634 {56.2}
		ISO 14,478 {64.4}	13,129 {58.4}

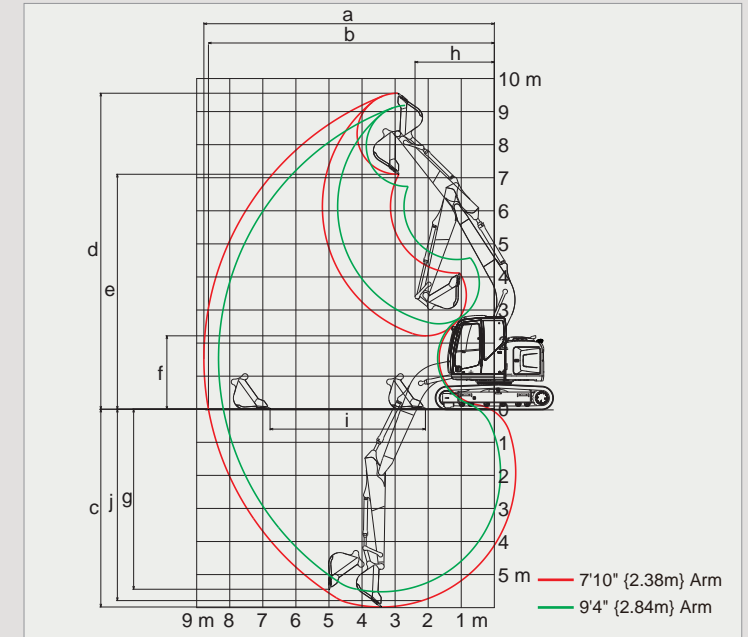

## Dimensions

Unit: ft-in{mm}

Arm length	7'10" {2.38m}	9'4" {2.84m}
<b>A Overall length</b>	24'7" {7,500}	24'7" {7,500}
<b>B Overall height (to top of boom)</b>	8'11" {2,730}	10'2" {3,110}
<b>C Overall width of crawler</b>	8'6" {2,590}**	
<b>D Overall height (to top of cab)</b>	9'5" {2,860}	
<b>E Ground clearance of rear end*</b>	33.7" {855}	
<b>F Ground clearance*</b>	17.3" {440}	

Unit: ft-in{mm}

<b>G Tail swing radius</b>	4'11" {1,490} (5'3" {1,600}***)
<b>H Tumbler distance</b>	9'12" {3,040}
<b>I Overall length of crawler</b>	12'4" {3,750}
<b>J Track gauge</b>	6'6" {1,990}
<b>K Shoe width</b>	19.7" {500} / 23.6" {600} / 27.6" {700}
<b>L Overall width of upperstructure</b>	8'2" {2,490}

\* Without including height of shoe lug  
\*\* Shoe width : 23.6" {600mm}  
\*\*\* With add-on type counterweight

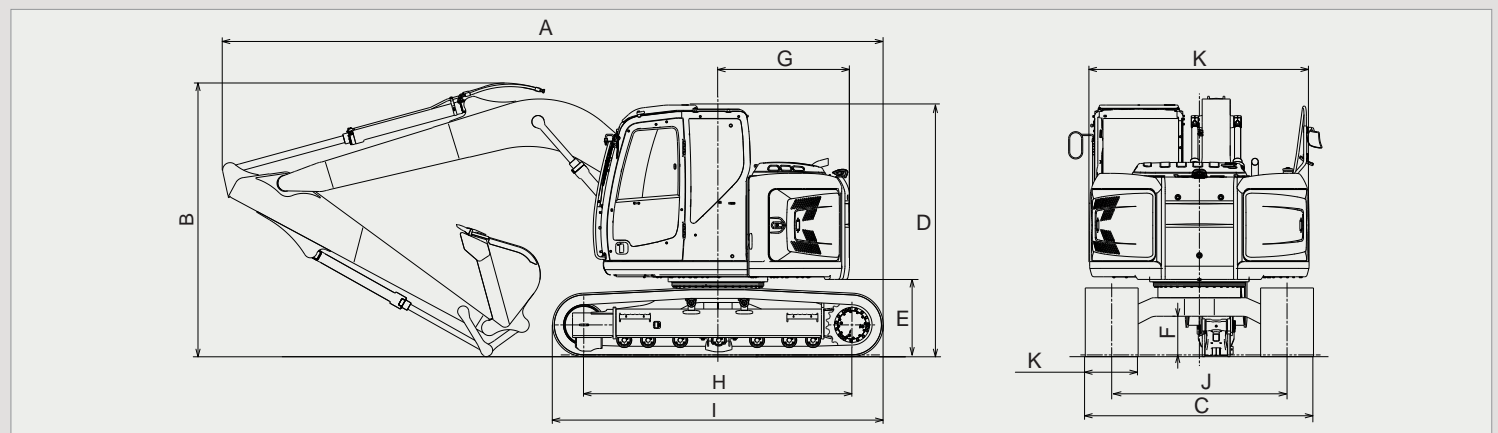

## Operating Weight & Ground Pressure

In standard trim, with standard boom, 9'4" {2.84m} arm, and 0.50 cu.yd. {0.38m<sup>3</sup>} SAE heaped bucket

Shaped	Triple grouser shoes (even height)		
	Shoe width	Overall width of crawler	Ground pressure
<b>Shoe width</b>	19.7" {500}	23.6" {600}	27.6" {700}
<b>Overall width of crawler</b>	8'2" {2,490}	8'6" {2,590}	8'10" {2,690}
<b>Ground pressure</b>	6.0 {41}	5.1 {35}	4.4 {31}
<b>Operating weight</b>	30,400 {13,800}	31,100 {14,100}	31,500 {14,300}
<b>Dozer (optional)</b>			
<b>weight</b>	32,100 {14,600}	32,800 {14,900}	33,200 {15,100}
<b>Ground pressure</b>	6.3 {44}	5.4 {37}	4.7 {32}

### Offset Boom Specifications

#### Working Ranges

Unit: ft-in{m}

Boom	Offset Boom Specification					
	7'3" {2.20 m}			8'2" {2.50 m}		
	Max. Left	Center	Max. Right	Max. Left	Center	Max. Right
a- Max. digging reach	23'5" {7,150}	24'10" {7,570}	23'5" {7,140}	24'4" {7,410}	25'8" {7,830}	24'3" {7,400}
b- Max. digging reach at ground level	22'11" {6,980}	24'4" {7,410}	22'10" {6,970}	23'9" {7,250}	25'2" {7,680}	23'9" {7,230}
c- Max. digging depth	14'10" {4,520}	16'2" {4,920}	14'9" {4,500}	15'10" {4,820}	17'2" {5,220}	15'9" {4,800}
d- Max. digging height	25'7" {7,810}	26'9" {8,150}	25'7" {7,800}	26'2" {7,970}	27'3" {8,310}	26'1" {7,960}
e- Max. dumping clearance	17'9" {5,420}	18'11" {5,770}	17'9" {5,410}	18'4" {5,590}	19'5" {5,930}	18'3" {5,570}
f- Min. dumping clearance	6'9" {2,070}	7'11" {2,410}	6'9" {2,050}	5'10" {1,780}	6'11" {2,120}	5'10" {1,770}
g- Max. vertical wall digging depth	10'8" {3,250}	11'10" {3,600}	10'7" {3,230}	11'7" {3,540}	12'10" {3,900}	11'7" {3,530}
h- Min. swing radius	5'1" {1,810}	5'8" {1,720}	6'9" {2,050}	6'3" {1,900}	5'10" {1,790}	6'11" {2,110}
i- Horizontal digging stroke at ground level	12'4" {3,770}	12'0" {3,750}	12'4" {3,770}	13'11" {4,230}	13'10" {4,210}	13'11" {4,230}
j- Digging depth for 8 feet flat bottom	13'8" {4,160}	15'0" {4,560}	13'7" {4,140}	14'8" {4,480}	16'0" {4,880}	14'8" {4,470}
Bucket capacity SAE heaped cu.yd. {m <sup>3</sup> }	0.59 {0.45}			0.50 {0.38}		

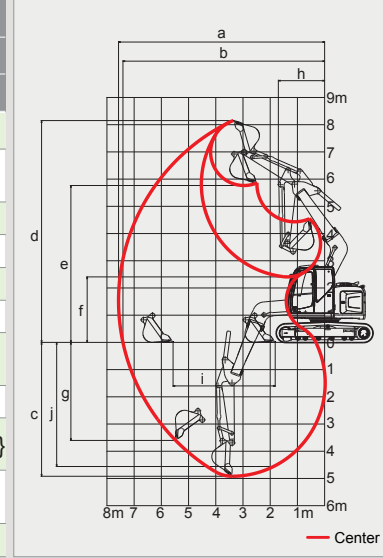

### Dimensions

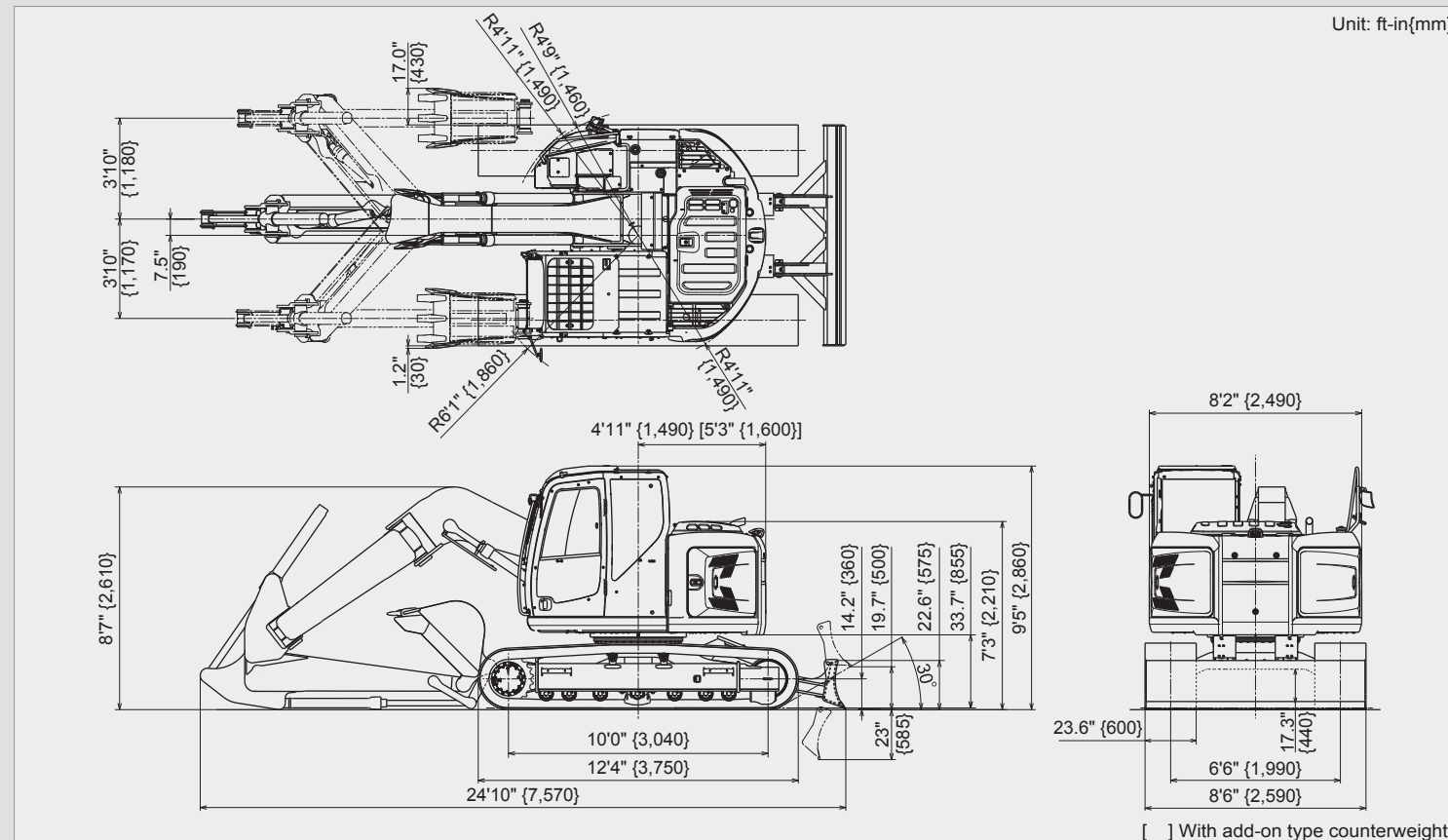

### Operating Weight & Ground Pressure

In standard trim, with standard boom, 7'3" {2.20m} arm, and 0.59 cu.yd. {0.45m<sup>3</sup>} SAE heaped bucket

Shaped	Triple grouser shoes (even height)		
	ft-in {mm}		
Shoe width	19.7" {500}	23.6" {600}	27.6" {700}
Overall width of crawler	8'2" {2,490}	8'6" {2,590}	8'10" {2,690}
Ground pressure	6.24 {43}	5.22 {36}	4.64 {32}
Operating weight	31,700 {14,400}	32,400 {14,700}	32,800 {14,900}



A – Reach from swing centerline for bucket hook  
B – Bucket hook height above/below ground  
C – Lifting capacities in pounds

SK140SRLC Arm: 9'4" {2.84m} Bucket: 0.50cu.yd. {0.38m <sup>3</sup> } SAE heaped 710 lbs {320kg} Counterweight ; 7,280 lbs {3,300kg} Shoe: 23.6" {600mm}														
		5' {1.5m}		10' {3.0m}		15' {4.6m}		20' {6.1m}		25' {7.6m}		At Max. Reach		
		Rating over front		Rating over side or 360 degrees		Rating over front		Rating over side or 360 degrees		Rating over front		Rating over side or 360 degrees		
A	B	Radius		Radius		Radius		Radius		Radius		Radius		
25' {7.6m}	lb(kg)											*3,310 {1,500}	*3,310 {1,500}	14'11" {4.54m}
20' {6.1m}	lb(kg)					*5,600 {2,540}	*5,600 {2,540}	*2,910 {1,310}	*2,910 {1,310}			*2,700 {1,220}	*2,700 {1,220}	20'1" {6.13m}
15' {4.6m}	lb(kg)					*6,160 {2,790}	*6,160 {2,790}	*5,800 {2,630}	*4,040 {1,830}			*2,520 {1,140}	*2,520 {1,140}	23'1" {7.04m}
10' {3.0m}	lb(kg)					*10,330 {4,680}	*10,330 {4,680}	*7,740 {3,510}	*6,400 {2,900}	*6,390 {2,890}	*3,810 {1,720}	*2,550 {1,150}	*2,460 {1,110}	24'8" {7.53m}
5' {1.5m}	lb(kg)					*15,700 {7,120}	*10,850 {4,920}	*9,720 {4,400}	*5,710 {2,590}	*6,060 {2,740}	*3,510 {1,590}	*3,300 {1,490}	*2,280 {1,030}	25'2" {7.68m}
G.L.	lb(kg)					*17,020 {7,720}	*9,730 {4,410}	*9,240 {4,190}	*5,170 {2,340}	*5,770 {2,610}	*3,250 {1,470}	*3,180 {1,440}	*2,240 {1,010}	24'8" {7.52m}
-5' {-1.5m}	lb(kg)	*10,050 {4,550}	*10,050 {4,550}	*17,710 {8,030}	9,450 {4,280}	8,950 {4,050}	4,920 {2,230}	5,620 {2,540}	3,110 {1,410}			*4,020 {1,820}	*2,480 {1,120}	23'0" {7.02m}
-10' {-3.0m}	lb(kg)	*15,720 {7,130}	*15,720 {7,130}	*15,180 {6,880}	9,590 {4,340}	8,960 {4,060}	4,920 {2,230}					*5,700 {2,580}	*3,180 {1,440}	20'0" {6.09m}
-15' {-4.6m}	lb(kg)				*9,790 {4,440}	*9,790 {4,440}						*6,130 {2,780}	*5,480 {2,480}	14'8" {4.47m}

SK140SRLC Arm: 9'4" {2.84m} Bucket: 0.50cu.yd. {0.38m <sup>3</sup> } SAE heaped 710 lbs {320kg} Counterweight ; 8,560 lbs {3,880kg} Shoe: 23.6" {600mm}														
		5' {1.5m}		10' {3.0m}		15' {4.6m}		20' {6.1m}		25' {7.6m}		At Max. Reach		
A	B	Radius		Radius		Radius		Radius		Radius		Radius		
25' {7.6m}	lb(kg)											*3,310 {1,500}	*3,310 {1,500}	14'11" {4.54m}
20' {6.1m}	lb(kg)					*5,600 {2,540}	*5,600 {2,540}	*2,900 {1,310}	*2,910 {1,310}			*2,700 {1,220}	*2,700 {1,220}	20'1" {6.13m}
15' {4.6m}	lb(kg)					*6,160 {2,790}	*6,160 {2,790}	*5,800 {2,630}	*4,540 {2,050}			*2,520 {1,140}	*2,520 {1,140}	23'1" {7.04m}
10' {3.0m}	lb(kg)					*10,330 {4,680}	*10,330 {4,680}	*7,740 {3,510}	*7,110 {3,220}	*6,550 {2,970}	*4,310 {1,950}	*2,550 {1,150}	*2,460 {1,110}	24'8" {7.53m}
5' {1.5m}	lb(kg)					*15,700 {7,120}	*12,130 {5,500}	*9,720 {4,400}	*6,430 {2,910}	*6,720 {3,040}	*4,010 {1,810}	*3,300 {1,490}	*2,670 {1,210}	25'2" {7.68m}
G.L.	lb(kg)					*17,020 {7,720}	*11,010 {4,990}	*10,220 {4,630}	*5,890 {2,670}	*6,430 {2,910}	*3,750 {1,700}	*3,180 {1,440}	*2,630 {1,190}	24'8" {7.52m}
-5' {-1.5m}	lb(kg)	*10,050 {4,550}	*10,050 {4,550}	*17,710 {8,030}	10,730 {4,860}	9,930 {4,500}	5,630 {2,550}	6,280 {2,840}	3,610 {1,630}			*4,020 {1,820}	*2,910 {1,310}	23'0" {7.02m}
-10' {-3.0m}	lb(kg)	*15,720 {7,130}	*15,730 {7,130}	*15,180 {6,880}	10,870 {4,930}	9,950 {4,510}	5,650 {2,560}					*5,970 {2,700}	*3,690 {1,670}	20'0" {6.09m}
-15' {-4.6m}	lb(kg)				*9,790 {4,440}	*9,790 {4,440}						*6,130 {2,780}	*5,480 {2,480}	14'8" {4.47m}

SK140SRLC Arm: 7'10" {2.38m} Bucket: 0.65cu.yd. {0.50m <sup>3</sup> } SAE heaped 860 lbs {360kg} Counterweight ; 7,280 lbs {3,300kg} Shoe: 23.6" {600mm}															
		5' {1.5m}		10' {3.0m}		15' {4.6m}		20' {6.1m}		At Max. Reach		Radius			
A	B	Radius		Radius		Radius		Radius		Radius		Radius			
25' {7.6m}	lb(kg)											*3,540 {1,600}	*3,540 {1,600}	12'2" {3.70m}	
20' {6.1m}	lb(kg)							*6,260 {2,830}	*6,260 {2,830}			*2,770 {1,250}	*2,770 {1,250}	18'2" {5.55m}	
15' {4.6m}	lb(kg)							*7,050 {3,190}	*7,050 {3,190}			*2,590 {1,170}	*2,590 {1,170}	21'5" {6.55m}	
10' {3.0m}	lb(kg)							*12,230 {5,540}	*12,230 {5,540}	*8,610 {3,900}	6,300 {2,850}	6,380 {2,890}	3,810 {1,720}	*2,650 {1,200}	23'2" {7.07m}
5' {1.5m}	lb(kg)							*17,220 {7,810}	10,620 {4,810}	9,830 {4,450}	5,690 {2,580}	6,100 {2,760}	3,550 {1,610}	*2,910 {1,310}	23'8" {7.23m}
G.L.	lb(kg)							*16,340 {7,410}	9,840 {4,460}	9,320 {4,220}	5,250 {2,380}	5,860 {2,650}	3,340 {1,510}	*3,450 {1,560}	23'2" {7.06m}
-5' {-1.5m}	lb(kg)	*11,710 {5,310}	*11,710 {5,310}	*17,290 {7,840}	9,750 {4,420}	9,130 {4,140}	5,080 {2,300}	5,770 {2,610}	3,260 {1,470}			*4,570 {2,070}	2,940 {1,330}	21'4" {6.52m}	
-10' {-3.0m}	lb(kg)	*18,190 {8,250}	*18,190 {8,250}	*14,080 {6,380}	9,990 {4,530}	9,220 {4,180}	5,170 {2,340}					*6,880 {3,120}	3,920 {1,770}	18'0" {5.51m}	

SK140SRLC Arm: 7'10" {2.38m} Bucket: 0.65cu.yd. {0.50m <sup>3</sup> } SAE heaped 860 lbs {360kg} Counterweight ; 8,560 lbs {3,880kg} Shoe: 23.6" {600mm}															
		5' {1.5m}		10' {3.0m}		15' {4.6m}		20' {6.1m}		At Max. Reach		Radius			
A	B	Radius		Radius		Radius		Radius		Radius		Radius			
25' {7.6m}	lb(kg)											*3,540 {1,600}	*3,540 {1,600}	12'2" {3.70m}	
20' {6.1m}	lb(kg)							*6,260 {2,830}	*6,260 {2,830}			*2,770 {1,250}	*2,770 {1,250}	18'2" {5.55m}	
15' {4.6m}	lb(kg)							*7,050 {3,190}	*7,050 {3,190}			*2,590 {1,170}	*2,590 {1,170}	21'5" {6.55m}	
10' {3.0m}	lb(kg)							*12,230 {5,540}	*12,230 {5,540}	*8,610 {3,900}	7,030 {3,180}	7,030 {3,180}	4,310 {1,950}	*2,650 {1,200}	23'2" {7.07m}
5' {1.5m}	lb(kg)							*17,220 {7,810}	11,900 {5,390}	*10,440 {4,730}	6,420 {2,910}	6,750 {3,060}	4,060 {1,840}	*2,910 {1,310}	23'8" {7.23m}
G.L.	lb(kg)							*16,340 {7,410}	11,120 {5,040}	10,300 {4,670}	5,980 {2,710}	6,520 {2,950}	3,850 {1,740}	*3,450 {1,560}	23'2" {7.06m}
-5' {-1.5m}	lb(kg)	*11,710 {5,310}	*11,710 {5,310}	*17,290 {7,840}	11,030 {5,000}	10,110 {4,580}	5,810 {2,630}	6,420 {2,910}	3,760 {1,700}			*4,570 {2,070}	3,410 {1,540}	21'4" {6.52m}	
-10' {-3.0m}	lb(kg)	*18,190 {8,250}	*18,190 {8,250}	*14,080 {6,380}	11,270 {5,110}	9,470 {4,290}	5,890 {2,670}					*7,170 {3,250}	4,490 {2,030}	18'0" {5.51m}	

Notes:

- Do not attempt to lift or hold any load that is greater than these lift capacities at their specified lift point radius and heights. Weight of all accessories must be deducted from the above lift capacities.
- Lift capacities are based on machine standing on level, firm, and uniform ground. User must make allowance for job conditions such as soft or uneven ground, out of level conditions, side loads, sudden stopping of loads, hazardous conditions, experience of personnel, etc.
- Bucket lift hook is defined as lift point.
- The above lifting capacities are in compliance with SAE J1507. They do not exceed 87 % of hydraulic lifting capacity or 75 % of tipping load. Lifting capacities marked with an asterisk (\*) are limited by hydraulic capacity rather than tipping load.
- Operator should be fully acquainted with the Operator's and Maintenance Instructions before operating this machine. Rules for safe operation of equipment should be adhered to at all times.
- Lift capacities apply to only machines as originally manufactured and normally equipped by KOBELCO CONSTRUCTION MACHINERY CO., LTD.